

VoidForm®

RMAX
Innovation working for you

WAFFLE RAFT SLAB SYSTEM

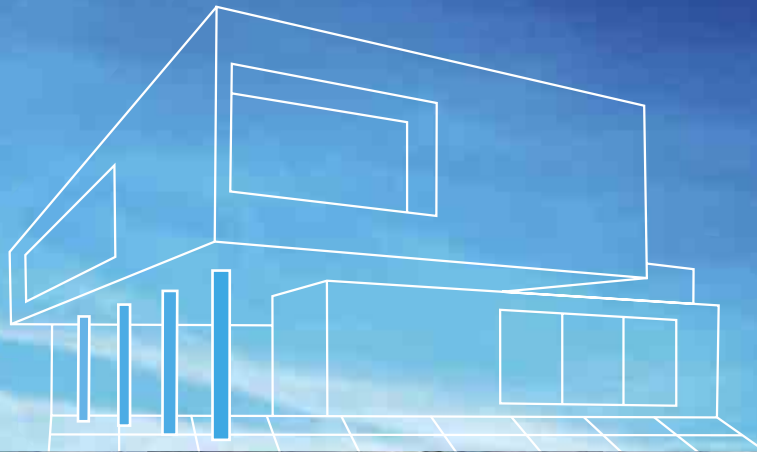

The perfect
foundation
for innovation



WAFFLE RAFT SLAB SYSTEM



The perfect foundation for innovation

THE GREAT BASE FOR A GREAT JOB!

The **RMAX VoidForm®** System is an advanced system for waffle raft slab foundations, developed by RMAX to reduce concrete quantities, provide greater slab strength, increase energy efficiency and save costs and time for the builder. It provides speed and ease of use, reliability and improved slab quality together with lower costs.

The RMAX Void-Lock® Grid Spacer System

The RMAX Void-Lock® Grid Spacer System holds the voids in place during concrete pouring and speeds up preparation of the slab.

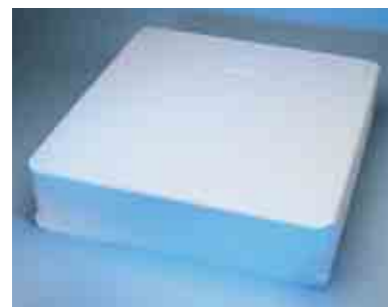

VoidForm®



Void-Lock®



Void-Lock® and VoidForm® locked together.

As they arrive on site, ready to use, labour costs are reduced to a minimum. It enables maximum control of every concrete pour. The RMAX VoidForm® System requires less preparation work and concrete usage is significantly reduced.

Made from RMAX Environmental EPS (expanded polystyrene) the VoidForm® System is unaffected by moisture. So no time is lost using them in wet weather and quality is maintained. They do not sag or buckle even in the most adverse of weather conditions.

The RMAX VoidForm® system improves the energy efficiency of houses. Its insulation features reduce energy costs, keeping your home cooler in summer and warmer in winter.

The system can be effectively used on sites of sand, rock, reactive soils and water tables. Beam excavation is eliminated and the voids are capable of spanning sewers and water mains without piers.

INSTALLATION

Every step in the installation of the RMAX VoidForm® system saves costs, reduces concrete quantities and provides greater slab strength and energy efficiency. The system ensures maximum control and reliability.



Step 1 The building site must be levelled, all plumbing pipes fixed in place and the formwork positioned.



Step 2 Plastic sheeting of 200 microns is spread over the site, with all laps taped.



Step 3 Starting from the corner of the site, lay VoidForms® in grid pattern, using Void-Lock® grid spacers. The VoidForms® can be easily cut to size and to fit plumbing fixtures.



Step 4 Place the reinforcement bars between the VoidForms® and the top mesh over the total area. Ensure tie laps are used as required.



Step 5 Place chairs under the mesh at a rate of 4 per VoidForm®.



Step 6 In a single concrete pour, partially cover the VoidForm® before filling the ribs. (This will help prevent the VoidForm® from floating).

DETAILS

This drawing is to be read in conjunction with Table 1 & Table 2. For VoidForm® height - H, Reinforcing fabric - F and Size of Y bar bottom reinforcement for each VoidForm® waffle raft slab type, refer to Table 1.

Stem Width Max	Additional Top Steel	Additional Bot. Steel
200mm	1-Y12	2-Y12
330mm	2-Y12	3-Y12
440mm	3-Y12	4-Y12

Type	VoidForm® Height	RIB Construction
1	225mm	RIB depth - 310mm O/A 1-Y12 Bot. F72 in top
2	300mm	RIB depth - 385mm O/A 1-Y12 Bot. F82/72 in top
3	300mm	RIB depth - 385mm O/A 1-Y16 Bot. F82 in top

NOTE 1
The next VoidForm® must be set down "L" is 600mm for Y16 bars and 450mm for Y12 bars. O/A denotes overall height.

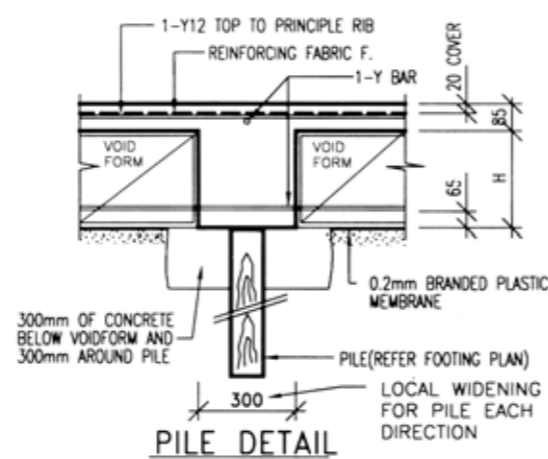
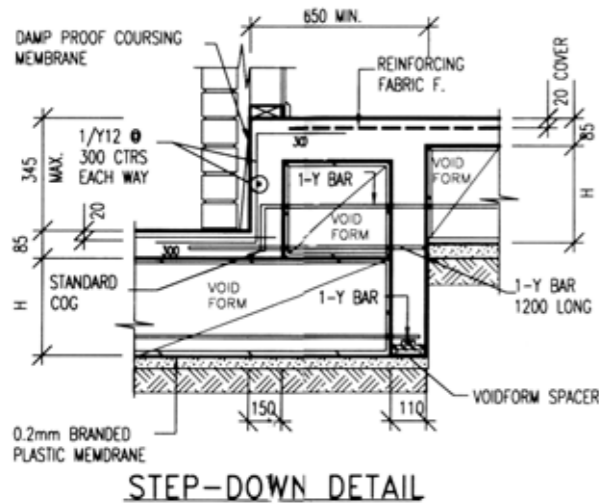
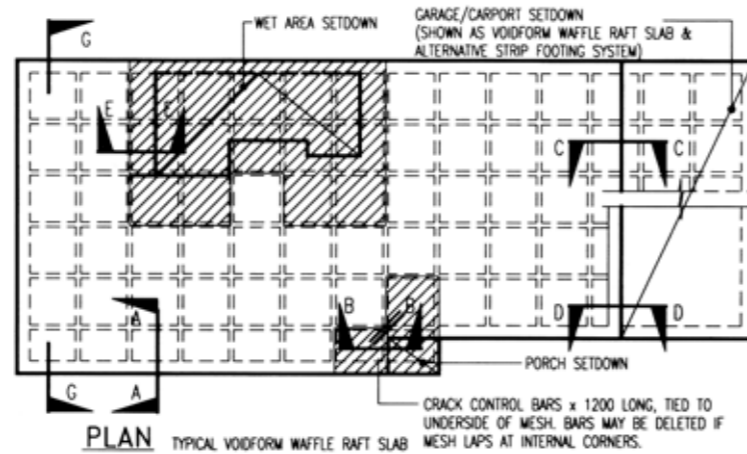

Notes

Surface fill, roots and vegetation are to be removed off the building platform.
Site is to be cut and/or filled to form a level bench to within approx 50mm. Up to 300mm of approved compacted fill may be used (refer AS 2870-1996). If additional fill is required or where a site has existing fill contact an engineer prior to further construction or design. Pressure required is 40KPa.
Place suitable quarry products (well graded quarry sands or rubble having a particle size of 4mm maximum) up to 50mm in depth to obtain a level platform within +/- 5mm. If the building platform

is level after the above mentioned site works, quarry material may not be required and only used in low areas. It is recommended that this material extends 1.0m past the building line.
A minimum RIB width of 110mm must be maintained where plumbing risers clash with RIBs. This may be achieved by cutting VoidForm® to suit and lapping reinforcement.
Concrete strength to be F'c=20MPa and is to be mechanically vibrated. Pour RIBs as part of slab.
This detail sheet shall be read in conjunction with the footing plan, architectural drawings, soil report and AS 2870-1996.

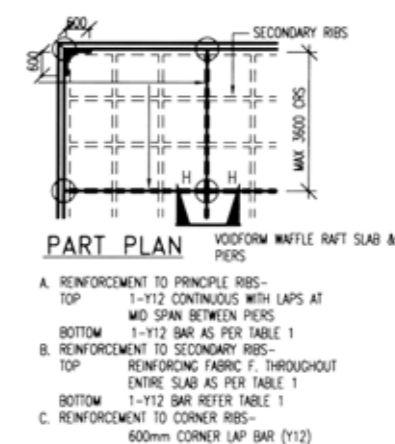
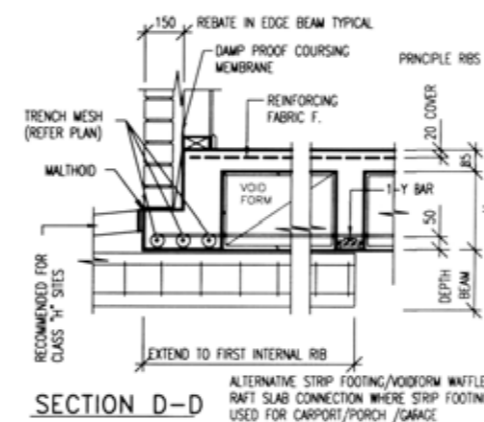
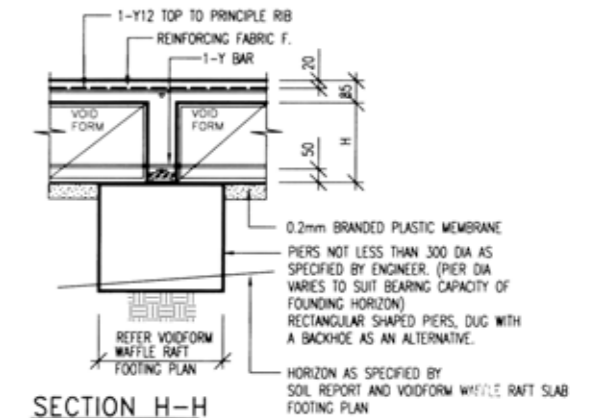
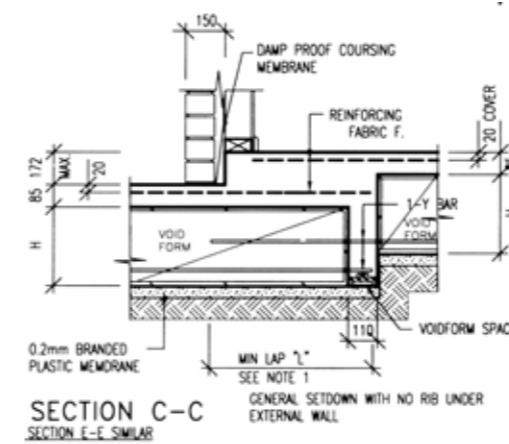
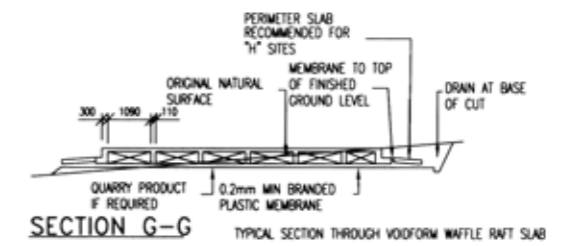
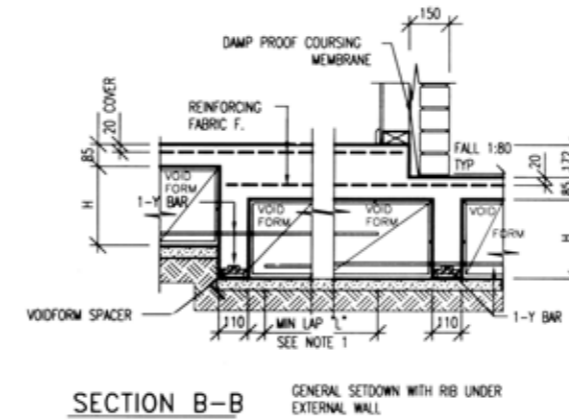
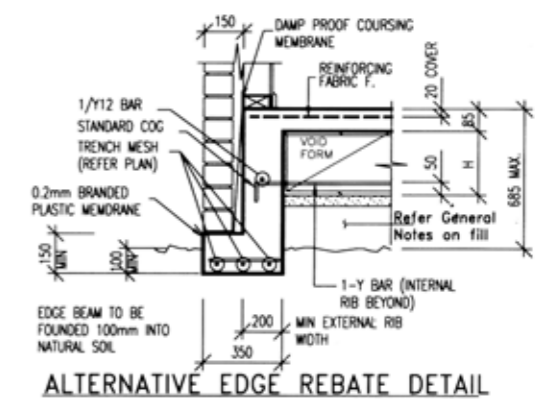
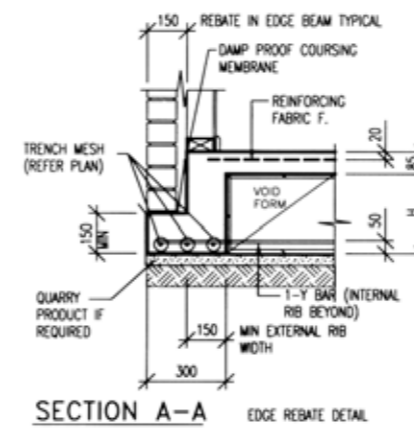

Note
Details are to be used as a guide only. Footing designs are to be designed by a suitably qualified engineer.
Reproduced with permission of Buratt Engineering Pty. Ltd.

PERFORMANCE COMPARISONS

Type of Construction

Site Classes VoidForm® Waffle Raft Slab Site Stiffened Raft Slab Sites ▲

		Depth of VoidForm®	Beam Depth (mm)	Bar Size Beam Reinforcement	Slab Fabric	Depth (D) (mm)	Bottom Reinforcement	Spacing Centre to Centre (m)	Slab Fabric
Class A	Clad frame, articulated masonry veneer and masonry veneer.	175mm	260	Y12	F72	300	3-8TM	-	F72
	Articulated full masonry and full masonry.	●	●	●	●	400	3-8TM	-	F82
Class S	Clad frame.	175mm	260	Y12	F72	300	3-8TM	-	F72
	Articulated masonry veneer.	175mm	260	Y12	F72	400	3-8TM	-	F82
	Masonry veneer	●	●	●	●	300	3-11TM	-	F82
	Articulated full masonry	●	●	●	●	400	3-11TM	-	F82
	Full masonry	●	●	●	●	450	3-11TM	5.0*	F82
Class M	Clad frame.	225mm	310	Y12	F72	300	3-11TM	6.0*	F72
	Articulated masonry veneer.	225mm	310	Y12	F72	400	3-11TM	6.0*	F72
	Masonry veneer	225mm	310	Y12	F72	400	3-11TM	5.0*	F72
	Articulated full masonry	●	●	●	●	500	3-11TM	4.0	F82
	Full masonry	●	●	●	●	800	3-Y16	4.0	F92
Class M-D	Clad frame.	225mm	310	Y12	F72	400	3-11TM	5.0*	F72
	Articulated masonry veneer.	225mm	310	Y12	F72	400	3-11TM	4.0	F72
	Masonry veneer	●	●	●	●	500	3-12	4.0	F82
	Articulated full masonry	●	●	●	●	625	3-12TM	4.0	F92
	Full masonry	●	●	●	●	-	-	-	-
Class H	Clad frame.	225mm	310	Y12	F72	400	3-11TM	5.0*	F72
	Articulated masonry veneer.	300mm	385	Y12	F82	500	3-12TM	4.0	F82
	Masonry veneer	●	●	●	●	700	3-Y16	4.0	F92
	Articulated full masonry	●	●	●	●	1000	4-Y16	4.0	F102
	Full masonry	●	●	●	●	-	-	-	-
Class H-D	Clad frame.	300mm	385	Y16	F72	500	3-11TM	4.0	F82
	Articulated masonry veneer.	300mm	385	Y16	F82	600	3-12TM	4.0	F92
	Masonry veneer	●	●	●	●	-	-	-	-
	Articulated full masonry*	●	●	●	●	1200	4-Y16	4.0	F102
	Full masonry	●	●	●	●	-	-	-	-

▲ For further information refer to AS 2870 – 1996 page 21, note 1. * For further information refer to AS 2870 – 1996 page 21, note 8. ● Engineered option to site requirement.

Depth of VoidForm®	VoidForm® Waffle Raft Proportions
225mm	Type 1 - Rib depth is 310mm overall with 1/Y12 bottom and F72 top
300mm	Type 2 - Rib depth is 385mm overall with 1/Y12 bottom and F72 top
300mm	Type 3 - Rib depth is 385mm overall with 1/Y16 bottom and F82 top
375mm	Type 4 - Rib depth is 460mm overall with 1/Y12 bottom and F82 top
	Type 5 - Rib depth is 610mm overall with 1/Y16 bottom and F82 top
	(in addition 1/Y16 is required in the perimeter [N1]rib)

GUIDE ONLY: details to be verified by an Engineer.

Note: All types have slab thickness of 85mm. All rib depths measured from top of slab (all ribs 110mm wide)

CASE STUDIES

Case Study 1
TOWNSVILLE WHARF Queensland

The Challenge

To build a 3 storey house on a canal estate. A formidable task, given the presence of the watertable and Council restrictions on the height of the roofline.

The Solution

By reducing the thickness of each suspended concrete floor, RMAX VoidForm® Waffle Raft Slab system permitted the house to comply with the restrictions of both the watertable and the Council by-laws.

The VoidForm® Waffle Raft Slab eliminated the need for large concrete beams at the perimeter of the building.

RMAX VoidForms® are totally unaffected by moisture.

Case Study 2
FORESTDALE Queensland

The Challenge

Spanning a council's sewer main.

The Solution

Faced with the option of building a smaller house or spanning the sewer, the choice was the latter. This was achieved by the strength of the VoidForm® Waffle Raft Slab which allowed it to be suspended over the sewer without piers. A great saving in time and money.

RMAX VoidForm® waffle raft slab systems are capable of spanning sewers and water mains without piers.

Case Study 3
OAKDEN South Australia

The Challenge

To reduce costs on excavation footings.

The Solution

By applying the VoidForm® Waffle Raft Slab there was a significant reduction in excavation requirements, and combined with the elimination of the need for footings, the desired cost saving was achieved.

RMAX VoidForms® need no assembly: they arrive on site ready to use.



RMAX VoidForm® System meeting the challenge ...every time!

Case Study 4
OTTOWAY South Australia

The Challenge

The presence of floating rock on the building site.

The Solution

The unknown quantity of floating rock signalled an escalation of costs using the conventional footing slab. The engineers preference for a VoidForm® Waffle Raft Slab not only saved costs, but importantly, achieved a secured foundation on this problem site.

The quality standard of the finished job is assured with RMAX VoidForms®

Case Study 5
MALVERN Victoria

The Challenge

To erect 2 town houses, economically, on soft, silty soil, with a depth of 800mm to natural clay.

The Solution

The initial design was based on a conventional stiffened raft slab. By converting to a VoidForm® Waffle Raft Slab, the cost was reduced by approximately \$6,000.

The RMAX VoidForm® System provides ease of use, reliability, lower costs.

Case Study 6
DONCASTER Victoria

The Challenge

To provide a competitive alternative to a construction of units using screw-in piles.

The Solution

A redesign of the development to use a combination of bulk concrete piers and VoidForm® Waffle Raft Slab. A system that saved the builder thousands of dollars.

RMAX VoidForms® can be used effectively on sites where sand, reactive soils and water tables are a problem.



RMAX Environmental EPS

RMAX and the Environment

EPS (Expanded Polystyrene) is highly energy efficient. The energy saved over the lifetime of an EPS insulation panel in reduced heating demand, more than compensates for the raw material used in it's production.

The effective application of EPS insulation can cut carbon dioxide emissions by up to 50%. The energy used in it's manufacture is recovered within six months by the energy saved in the buildings when EPS is used to insulate the building.

RMAX EPS products do not contain ozone depleting substances and none is used in it's manufacture.

RMAX promotes the use of EPS, with it's superior thermal insulation properties, for the construction of buildings to lower energy requirements and reduce the impact of new buildings on the environment.

Recycling EPS

EPS products are recyclable and RMAX has established recycling facilities in all of our plants throughout Australia.

RMAX is a member of PACIA (Plastics and Chemical industries Association) and helped establish the EPS Industry Group, known as REPSA (Recycling Expanded Polystyrene Australia). RMAX, through REPSA play a major role in facilitating the collection and recycling of EPS in Australia.

Energy Efficient Manufacture

The manufacture of EPS is a low pollution process. Steam is the key ingredient and the water is used many times. There is no waste in production as all offcuts or rejects are re-used.

RMAX - Innovation Working for You

RMAX is a company driven by innovation. We have pioneered Rigid Cellular Plastics product technologies, leading the development of innovative product solutions for our customers and international partners.

In the Australian building industry, RMAX was the first to introduce termite resistant expanded polystyrene (EPS) - Isolite® Perform Guard® EPS. The exclusive patented technology incorporates a safe, non-toxic inorganic additive that is a deterrent to termites.

Identified by its grey colour, this material has been incorporated into ThermaWallPlus™ reinforced EPS exterior cladding to create a unique and valuable material for the building industry.

We are committed to working with our customers to deliver high quality creative solutions to construction problems. Contact us and see how our innovative approach using EPS in building construction can help you.



All Greenhouse Gas emissions associated with printing this product have been offset.

This product is 100% Carbon Neutral



www.rmax.com.au

AUSTRALIA

VICTORIA

2-4 Mephan Street
Maribyrnong VIC 3032
Locked Bag 51,
West Footscray VIC 3012
Telephone: +61 3 8319 6822
Facsimile: +61 3 9317 7888

WESTERN AUSTRALIA

5 Baldwin Street
Kewdale WA 6105
Telephone: +61 8 9353 1000
Facsimile: +61 8 9353 2002

SOUTH AUSTRALIA

Peachey Road
Elizabeth West SA 5113
Telephone: +61 8 8255 8022
Facsimile: +61 8 8255 7939

TASMANIA

22 Merino Street
Kings Meadows TAS 7249
Telephone: +61 3 6344 5644
Facsimile: +61 3 6344 2913

NEW SOUTH WALES

27 Chifley Street
Smithfield NSW 2164
Telephone: +61 2 9609 6088
Facsimile: +61 2 9604 7747

QUEENSLAND

236 Musgrave Road
Coopers Plains QLD 4108
Telephone: +61 7 3277 4522
Facsimile: +61 7 3277 7761



NEW ZEALAND

Barnes Plastics
368 Church Street
Penrose Auckland 1061
Telephone: +64 9 579 9725
Facsimile: +64 9 579 0472



Mixed Sources
Product group from well-managed forests and recycled wood or fiber
www.fsc.org Cert no. SGS-COC-2586
© 1996 Forest Stewardship Council

By buying products with an FSC Label, you are supporting the growth of responsible forest management worldwide

