



RMAX Recyclable EPS

RMAX and the Environment

EPS (Expanded Polystyrene) is highly energy efficient. The energy saved over the lifetime of an EPS insulation panel in reduced heating and cooling demand, more than compensates for the raw material used in its production.

The effective application of EPS insulation can cut carbon dioxide emissions by up to 50%. The energy used in its manufacture is recovered within six months by the energy saved in the buildings when EPS is used to insulate the building.

RMAX EPS products do not contain ozone depleting substances and none are used in its manufacture.

RMAX promotes the use of EPS, with its superior thermal insulation properties, for the construction of buildings to lower energy requirements and reduce the impact of new buildings on the environment.

RMAX EPS is free from ozone depleting substances in manufacture and composition. EPS is made without CFCs, HCFCs or HFCs. Manufacturing is done with blowing agents that have Zero Ozone Depleting Potential (ODP).

Recycling EPS

EPS products are recyclable and RMAX has established recycling facilities in all of its plants throughout Australia.

RMAX is a member of PACIA (Plastics and Chemical Industries Association) and helped establish the EPS Industry Group, known as EPSA (Expanded Polystyrene Australia). RMAX, through EPSA play a major role in facilitating the collection and recycling of EPS in Australia.

Energy Efficient Manufacture

The manufacture of EPS is a low pollution process. Steam is the key ingredient and the water is used many times. There is no waste in production as all off cuts or rejects are re-used.

RMAX - Innovation Working for You

RMAX is a company driven by innovation. We have pioneered Rigid Cellular Plastics product technologies, leading the development of innovative product solutions for our customers and international partners.

In the Australian building industry, RMAX was the first to introduce termite resistant expanded polystyrene (EPS) - Isolite® Perform Guard® EPS. The exclusive patented technology incorporates a safe, non-toxic inorganic additive that is a deterrent to termites.

Identified by its grey colour, this material has been incorporated into ThermaWallPlus®. Other new and innovative products from RMAX are ThermaWallSilver® and ThermaProof®. For details on these and other products in our range, visit www.rmax.com.au.

We are committed to working with our customers to deliver high quality creative solutions to construction problems. Contact us and see how our innovative approach using EPS in building construction can help you.

Developed in Australia. Made in Australia.

ThermaWallPlus® has been developed in Australia by RMAX specifically for Australian conditions and to meet the stringent Australian Building codes in all states. It is manufactured in RMAX plants in Australia in controlled production processes to maintain consistent quality.



All Greenhouse Gas emissions associated with the printing of this product have been offset.

This product is 100% Carbon Neutral



www.rmax.com.au
Enquires 1300 888 972

AUSTRALIA

VICTORIA

2-4 Mephan Street
Maribyrnong VIC 3032
Locked Bag 51,
West Footscray VIC 3012
Telephone: +61 3 8319 6822
Facsimile: +61 3 9317 2077

WESTERN AUSTRALIA

5 Baldwin Street
Kewdale WA 6105
Telephone: +61 8 9353 1000
Facsimile: +61 8 9353 2002

SOUTH AUSTRALIA

Peachey Road
Elizabeth West SA 5113
Telephone: +61 8 8255 8022
Facsimile: +61 8 8255 7939

TASMANIA

22 Merino Street
Kings Meadows TAS 7249
Telephone: +61 3 6344 5644
Facsimile: +61 3 6344 2913

NEW SOUTH WALES

27 Chifley Street
Smithfield NSW 2164
Telephone: +61 2 9609 6088
Facsimile: +61 2 9604 7747

QUEENSLAND

236 Musgrave Road
Coopers Plains QLD 4108
Telephone: +61 7 3277 4522
Facsimile: +61 7 3277 7761



NEW ZEALAND

Barnes
368 Church Street
Penrose Auckland 1061
Telephone: +64 9 579 9725
Facsimile: +64 9 579 0472



Mixed Sources

Product group from well-managed forests and other controlled sources
www.fsc.org Cert no. SGS-COC-2586
© 1996 Forest Stewardship Council

By buying products with an FSC Label, you are supporting the growth of responsible forest management worldwide

The pictures and illustrations shown in this brochure are for illustrative purposes only to demonstrate creativity and design and construction flexibility. They do not imply that ThermaWallPlus® was used in their construction.



RMAX is a division of Huntsman Chemical Company Australia Pty. Limited. ABN 48 004 146 338

Technical Data Manual



Contents

Introduction	2
Design Criteria	3
Installation Guidelines	4
Technical Specifications	5
Installation and Fixing Details	6
Pre-render Preparation	18
General Information	19
Warranty	20
Referenced Documents and Information	21

RMAX® ThermaWallPlus®

INTRODUCTION

RMAX® ThermaWallPlus® is an Australian made and distributed exterior insulation and finishing system (EIFS) which has been independently tested by NATA accredited testing laboratories to meet and exceed relevant Australian Standards for external building insulating cladding products. RMAX® ThermaWallPlus® has been approved and accredited by the Building Regulations Advisory Committee (BRAC) under BRAC Certificate Number V11/01.

Basic composition

ThermaWallPlus® building panels are made up of Perform Guard® – Termite Resistant expanded polystyrene (Grade M) core reinforced with high strength alkaline resistant fibreglass mesh and the ThermaWallPlus® enhanced surface coating, to provide strength and high impact resistance.

The ThermaWallPlus® coating is a durable textured surface ready to accept renders to achieve a variety of finishes. Contact your local architectural coating manufacturer for products that suit ThermaWallPlus® building panels and for an application specification.

ThermaWallPlus® description

ThermaWallPlus® offers the ThermaWallPlus® coating on one side and is suitable for both straight and curved wall applications.

Standard panel sizes and surface mass

The standard panel size is 2500mm x 1200mm, in nominal standard thicknesses of 40mm, 60mm, 75mm and 100mm.

The surface mass of each panel is given in Table 1.

Table 1: Nominal surface mass (kg/m²)

	40mm	60mm	75mm	100mm
ThermaWallPlus®	2.3	2.6	2.9	3.4



DESIGN CRITERIA

Installation design

All installation, erection and fixing requirements must be in accordance with details contained in this manual and the requirements of your local Building Authority.

Frame structure

The frame structure must be built in accordance with the Building Code of Australia (BCA) and with the relevant Australian Standards, for instance, AS 1684-1999 for Timber Frame and AS 3623-1993 for Steel Frame.

Fasteners

Each fastener is composed of:

- 1 screw
- 1 washer

Details of each component are given in Table 2.

Table 2: Fixing components details

Fasteners	Timber frame	Steel frame
Screw (40mm panel)	10G x 65mm CSK Head Coarse Ribbed Class 3	10G x 55mm Wing Tek Class 3
Screw (60mm panel)	10G x 85mm CSK Head Coarse Ribbed Class 3	10G x 75mm Wing Tek Class 3
Screw (75mm panel)	10G x 100mm CSK Head Coarse Ribbed Class 3	10G x 90mm Wing Tek Class 3
Screw (100mm panel)	10G x 125mm CSK Head Coarse Ribbed Class 3	10G x 115mm Wing Tek Class 3
Washer	40mm diameter plastic ThermaWallPlus® washer	

NOTE: Screw length is dependant on the thickness of the panel used. As a guide the screw should be minimum 25mm longer than the panel thickness for timber frame construction and 15mm longer than the panel thickness for steel frames.

The screw offset from the edge of the panels and the panel joins is to be 20mm. Where two panels butt up against each other, edge to edge, a double stud is to be used, allowing each panel to be fastened to its own individual stud. Please see fastener fixing detail on page 8 for further information.

Wind pressure design

The capacity of the ThermaWallPlus® external wall system, evaluated in accordance with the relevant Australian Standards (AS 4040.0, AS 4040.2, AS 4040.3), to resist against different categories of wind from Regions A, B (Non-Cyclonic) and C, D (Cyclonic) as requested by the BCA and defined according to AS/NZS 1170.2:2011 and AS 4055-2006 was obtained by several tests performed in accredited Laboratories (ref. 1, 2, & 5 through 9). Some testing was completed under the previous name for ThermaWallPlus® – all results remain valid for ThermaWallPlus® as no changes have been made to materials used and manufacturing sequence remains unchanged. Refer to page 21 for references.

The limitations of the following fixing provisions are:

- Building height to eaves or ridge ≤ 7.00 m
- Buildings built in terrain categories 1 to 3
- Buildings built on topographic classification T1 (AS 4055-2006).

The provisions of the fixing for the different wind regions A, B, C and D are defined in Table 3 below.

Table 3: Minimum Stud & Fastener Spacing for ThermaWallPlus® in accordance with AS 4055-2006

Wind category	Non-Cyclonic Regions (A & B)						Cyclonic Regions (C & D)			
	N1	N2	N3	N4	N5	N6	C1	C2	C3	C4
Stud spacing (mm)	450 or 600						450		300	
Fastener spacing (mm)	300 (150 at perimeter of wall)	300 (150 at perimeter of wall)	300 (150 at perimeter of wall)	200 (150 at perimeter of wall)	200 (150 at perimeter of wall)	200 (150 at perimeter of wall)	200 (150 at perimeter of wall)	200 (150 at perimeter of wall)	200 (150 at perimeter of wall)	200 (150 at perimeter of wall)
Number of fasteners/m²	12	12	12	18	18	18	18	18	18	18

PLEASE NOTE: Information in table 3 applies to ThermaWallPlus® panel thickness of 75mm & 100mm only. The application of 40mm and 60mm thick ThermaWallPlus® panel is only suitable for Non Cyclonic regions (A&B).

INSTALLATION GUIDELINES

Cutting of panel

For a clean, fast, accurate and no mess cut, we recommend using a standard diamond masonry blade or fibre cement blade. For more intricate cuts a hot knife or handsaw can be used.

Planning

Prior to installing ThermaWallPlus® panels, liaise with the builder to enable solid blocking to be installed where fixtures are to be fitted to the finished construction; e.g. Balustrade – Handrails, clothes lines, large light fittings, hot water services, air-conditioning units, etc.

Method of fixing

ThermaWallPlus® panels can be installed either vertically or horizontally. The panels are screwed directly to the frame. Screw heads and washers should be slightly recessed into the surface of the panel.

All joints between ThermaWallPlus® sheets should be glued with a polystyrene compatible construction adhesive.

Sheets should not be bonded (glued) to studs. This allows the frame to flex without stressing the external render.

Reinforce all joints with a 150mm minimum fiberglass strip of alkaline resistant 165 g/m² mesh trowelled over joint during first base coat render. The fiberglass strip is to be applied evenly and run the full length of the joint. Ensure that the panels are butted hard together.

Refer to Fastener Positioning detail on page 8.

Typical Corner and Joint details are to be adhered to. Refer to pages 9, 10 and 11.

Back Blocking of stud joints

Where sheet sides or ends do not finish on a stud, solid back blocking must be installed to strengthen and align joints.

Back blocks are cut from off cuts of stud material. The back blocks can be placed aligned with the joint or placed at 300mm centres perpendicular to the joint. Back blocks are to be nailed securely to frame.

ThermaWallPlus® panels are to be fixed to back blocks in same manner as fixing panels to the stud frame. Refer to Fastener Positioning detail on page 8.

Typical Corner and Joint details are to be adhered to. Refer to pages 9, 10 and 11.

Beading

All corners must be protected with UV stabilised PVC or aluminium bead. Any exposed edges (roof line, windows, doors, edge of concrete slab, etc.) should be covered with fiberglass mesh as specified on pages 9, 12 and 15 and finished with a cover bead, which will protect the panel from moisture and provide a clean finish line for coatings.

All beads should be fixed using a polystyrene compatible construction adhesive.

Starter Channels

ThermaWallPlus® panels are to be located in PVC or aluminium starter channels at the bottom edge of any ThermaWallPlus® wall as per ground slab detail on page 13.

Starter channels to include drainage weep holes (min 2mm diameter every 200mm) to allow moisture to escape. Typical bead detail can be found on pages 9-15.

Expansion (control) joints

Prior to installation determine expansion joint placement by consulting with a Design Engineer to calculate the deformation/stress due to soil/structure movement, deflection due to load bearing on roofing structures and to specify location of expansion/control joints.

Expansion joints must occur where ThermaWallPlus® meets other substrates/cladding materials.

This technical manual provides some practical details to perform the expansion joint. Refer to pages 10 and 11.

Sarking

Isolite® expanded polystyrene has a very low rate of water vapour transfer. However in line with good building practice RMAX requires the use of a breathable sarking to be fixed directly behind the ThermaWallPlus® panels.

It should be noted that ThermaWallPlus® installed in conjunction with a reflective breathable sarking will increase the overall thermal effectiveness of the wall system. Refer to Table 7 on page 5.

Render

Render to be of either polymer modified cement type or acrylic system that is suitable for use on expanded polystyrene. Examples of some rendered systems that could be applied are: Multitex RBS – Reinforced Board Render System, Granosite Granomarble, Acryloc Wallcote and Dulux Duspec amongst others. RMAX® provides examples of applicable render systems only as a guide. RMAX® takes no responsibility for render coating performance and effect on surface properties of ThermaWallPlus® panels. Render to be applied strictly in accordance with the render manufacturer's installation instructions/requirements at a minimum thickness of 5mm in 2 coats.

Curved wall applications

ThermaWallPlus® can be used in curved wall applications. Please refer to Table 4:

Table 4: Curved wall specifications

ThermaWallPlus® panel	Radius
40mm	> 2400mm
60mm	> 2400mm
75mm	> 4000mm

Masonry and concrete walls

Contact RMAX.

Adhesive: Glues including SikaFlex 11FC, Emerseal PU25, Enerfoam and a variety of polymer base renders have been used successfully.

Mechanical Fixings: Hilti IDP polypropylene anchors.

Installation: Walls must be cleaned prior to installation and free from dust, dirt, oil, vegetation and any loose or crumbling material.

The construction adhesive is applied evenly over the entire back of the panel. If using a polymer base render as your adhesive, a course notched trowel is used to spread the render evenly, again over the entire back of the panel

Use a minimum of 6 anchors with ThermaWallPlus® washers per square metre. It is important that the anchors are positioned evenly over the entire panel with corner anchors placed in close proximity to each panel corner.

Typical corner and joint details are to be adhered to. Refer to pages 9, 10 and 11.

Handling

Sheets should be stored elevated, under cover and laid flat. Edges and corners are to be protected at all times. ThermaWallPlus® should be rendered as soon as possible after installation. Prolonged exposure to elements should be avoided.

TECHNICAL SPECIFICATIONS

Thermal insulation

Table 5: R value of ThermaWallPlus® panel

Thickness (mm)	40	60	75	100
Thermal conductivity at 23°C (W/m2.K)	0.037			
R value at 23°C (m2.K/W)	1.10	1.60	2.05	2.70
Thermal conductance at 23°C (W/m2.K)	0.95	0.60	0.50	0.37

ThermaWallPlus® wall system thermal performance

From calculations by thermal calculation code recognised by CSIRO, the total R value for the complete ThermaWallPlus® wall system (see fig. 1) are given in Table 6.

Table 6: Total R value of ThermaWallPlus® wall system

Thickness (mm)	Total R value (m2.K/W)
40	1.50
60	2.00
75	2.45
100	3.10

ThermaWallPlus® installed with a reflective breathable sarking will increase the overall thermal effectiveness of the wall system.

Table 7: Total R value of ThermaWallPlus® wall system with reflective sarking

ThermaWallPlus® panel	Total R value
40mm	1.92
60mm	2.46
75mm	2.86
100mm	3.54

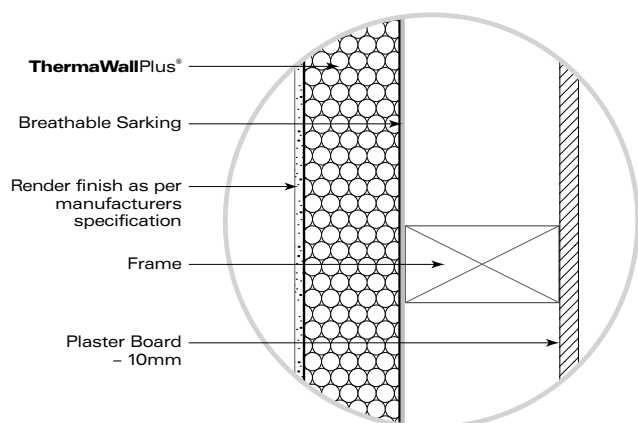

Figure 1: Example of the ThermaWallPlus® wall system

INSTALLATION AND FIXING DETAILS

Structural Bracing Capacity

The ThermaWallPlus® external wall system was tested in racking tests in accordance with AS 4040.0-1992, AS 4040.2-1992 and AS 4040.3-1992 for non-cyclonic and cyclonic conditions (Regions A, B, C and D) by an accredited Laboratory (ref. 5 and 6). Refer to page 21.

The obtained bracing capacity at 2.70m (as defined in AS 1684-1999 "Residential timber-framed construction" – Part.2: Non - cyclonic areas; Part.3: Cyclonic areas and Part. 4: Simplified – Non-cyclonic areas), in serviceability conditions are summarised in Table 8.

Table 8: Structural bracing capacity (kN/m at 2.70m height) of ThermaWallPlus® wall systems applicable in regions A & B (Non-cyclonic) and regions C & D (Cyclonic)

Panel	Frame reinforcement	Stud spacing (mm)	Fastener spacing (mm)				
			300	200	150	120	100
ThermaWallPlus®	Nil	450 or 600	1.15	1.35	1.40	1.50	1.55
ThermaWallPlus®	Bracing Reinforcement. Vertical 12mm diam steel rod at 500mm from the corner where the racking force is applied. Galvanised straps at the top only.	450 or 600					3.85

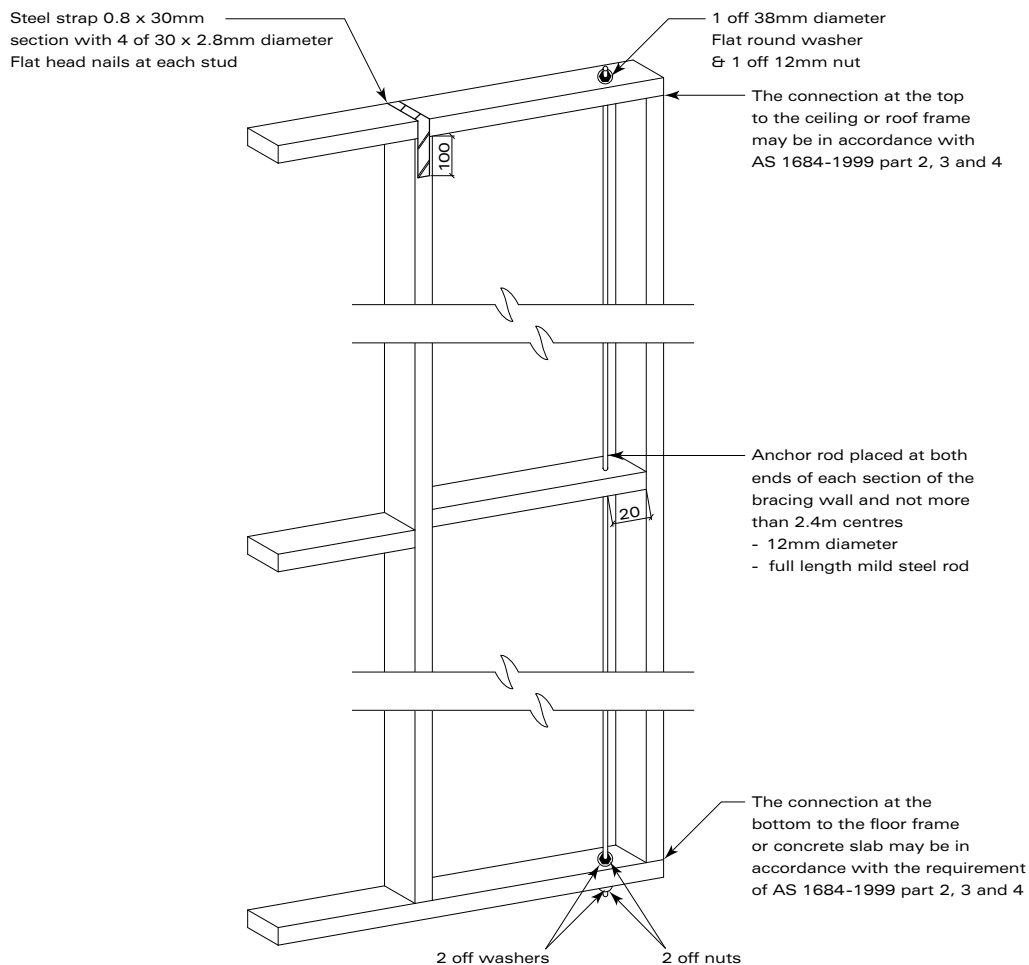

Bracing Reinforcement

Early fire hazard properties (AS/NZS 1530.3-1999)

From tests conducted by AWTA, Division of Building Material – NATA Accreditation # 1356, the following indices given in Table 9 have been determined.

Table 9: Early Fire Hazard properties of ThermaWallPlus®

Material	Ignitability Index (0-20)	Spread of Flame (0-10)	Heat Evolved Index (0-10)	Smoke Produced Index (0-10)
ThermaWallPlus®	0	0	0	4
An Australian Hardboard (4.75mm)				
– Bare	14	6	7	3
– Impregnated with fire retardant	4	0	0	7
An Australian Softboard (12.70mm)				
– Bare	16	9	7	3
– Impregnated with fire retardant	4	0	0	7
T&G Boarding (25 x 100mm)				
– Bluegum	11	0	3	2
– Oregon	13	6	5	3
Plywood, Coachwood Veneer (4.75mm)				
– Bare	15	7	7	4
– Impregnated with fire retardant	12	0	3	5

NOTE: The core material in ThermaWallPlus® is expanded polystyrene. As with all other organic material, insulation products must be considered combustible and to constitute a fire hazard if improperly used or installed. ThermaWallPlus® contains a flame retardant additive to inhibit accidental ignition from small fire sources.

Table 11: ThermaWallPlus® weighted sound reduction index (Rw) Performance

Panel Thickness mm	Construction	Rw
40	Panel only	11dB
75	Panel only	12dB
75	Panel + 5mm render	27dB
75	Panel + 5mm render + 10mm plaster. Full wall system	38dB

NOTE: The data in the above table was derived from RMAX M grade Orange Board sound transmission testing. The sound transmission performance of RMAX ThermaWallPlus® will be the same as Orange Board where the same EPS density grade and thickness has been tested.

Table 12: Perceived change in deibel levels

Change in Sound Level	Perceived Change to the Human Ear
+ 1dB – 1dB	Not perceptible
+ 3dB – 3dB	Threshold of perception
+ 5dB – 5dB	Clearly noticeable
+ 10dB – 10dB	Twice (or half) as loud
+ 20dB – 20dB	Fourfold (4x) change

NOTE: The threshold of perception of the human ear is approximately three decibels. A five decibel change is considered to be clearly noticeable to the ear whilst a ten decibel change would be perceived to be twice as loud.

INSTALLATION AND FIXING DETAILS

In Non Cyclonic Regions (A&B)

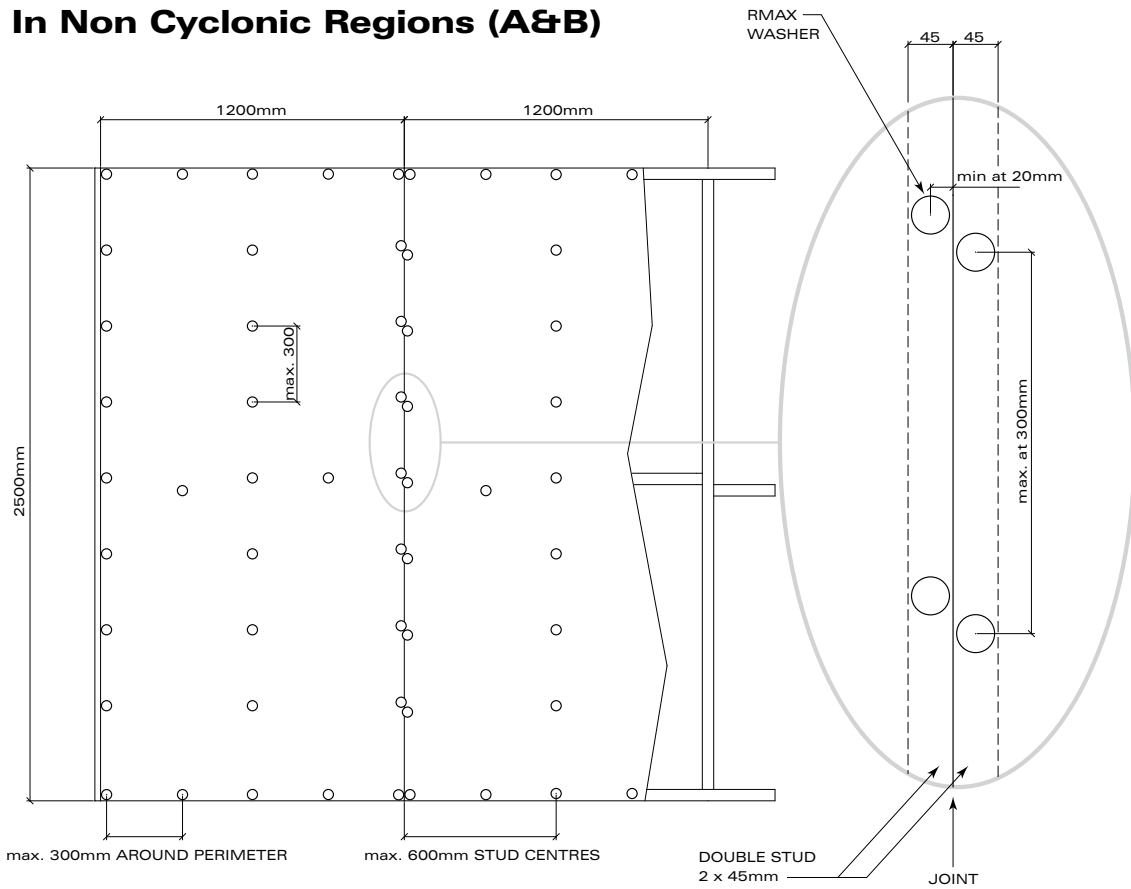

INSTALLATION AND FIXING DETAILS

In Cyclonic Regions (C&D)

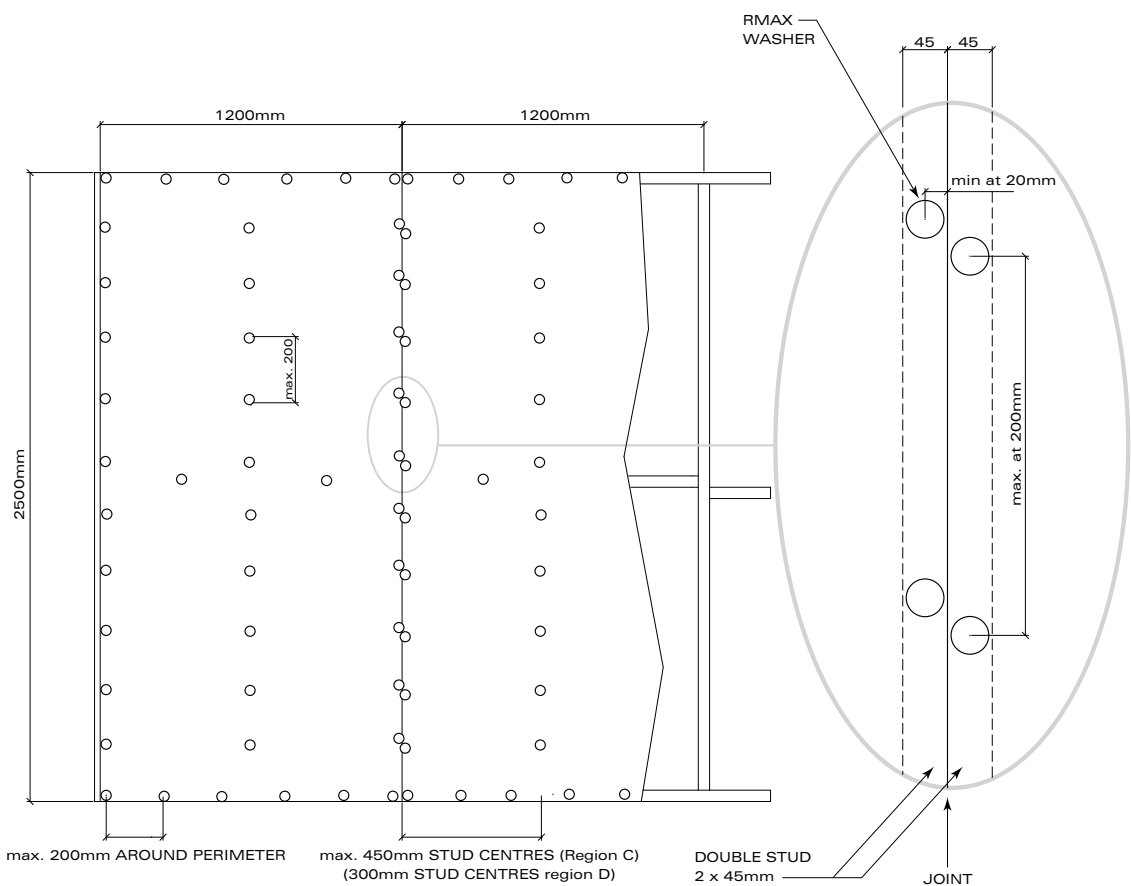

Corner Details

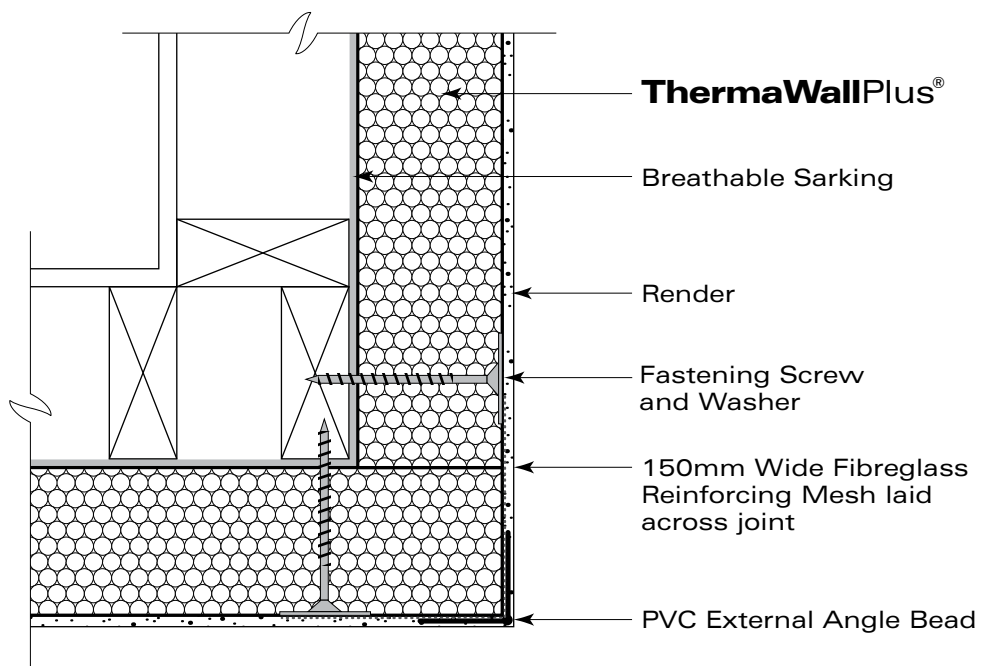
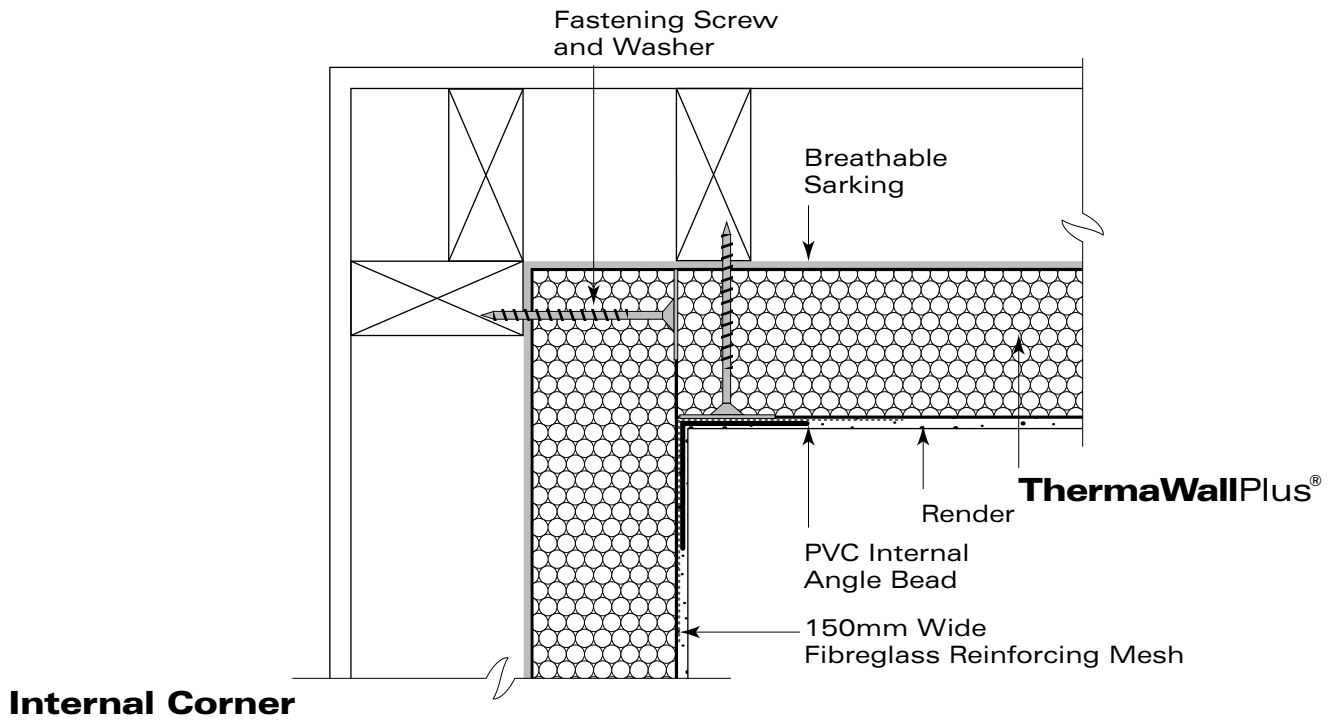

External Corner

INSTALLATION AND FIXING DETAILS

Expansion (Control) Joints

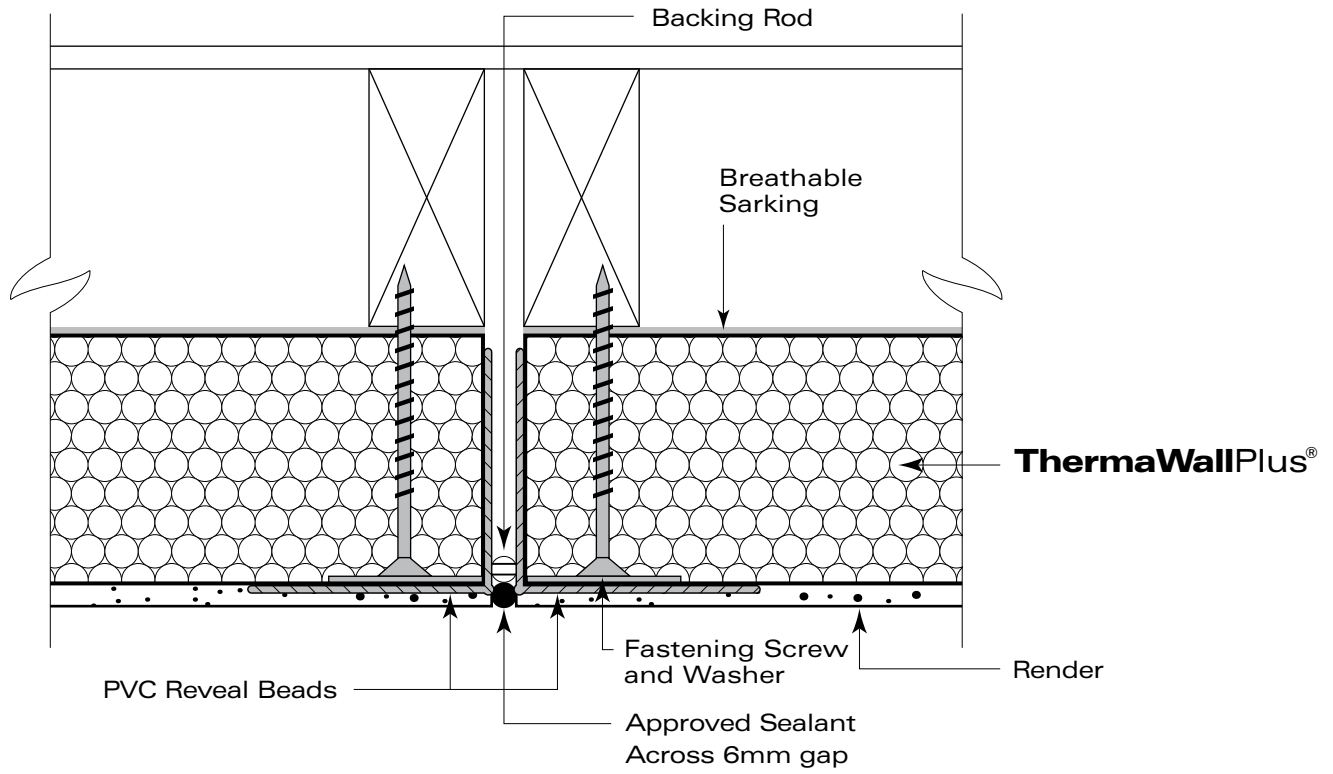

ThermaWallPlus® to ThermaWallPlus®

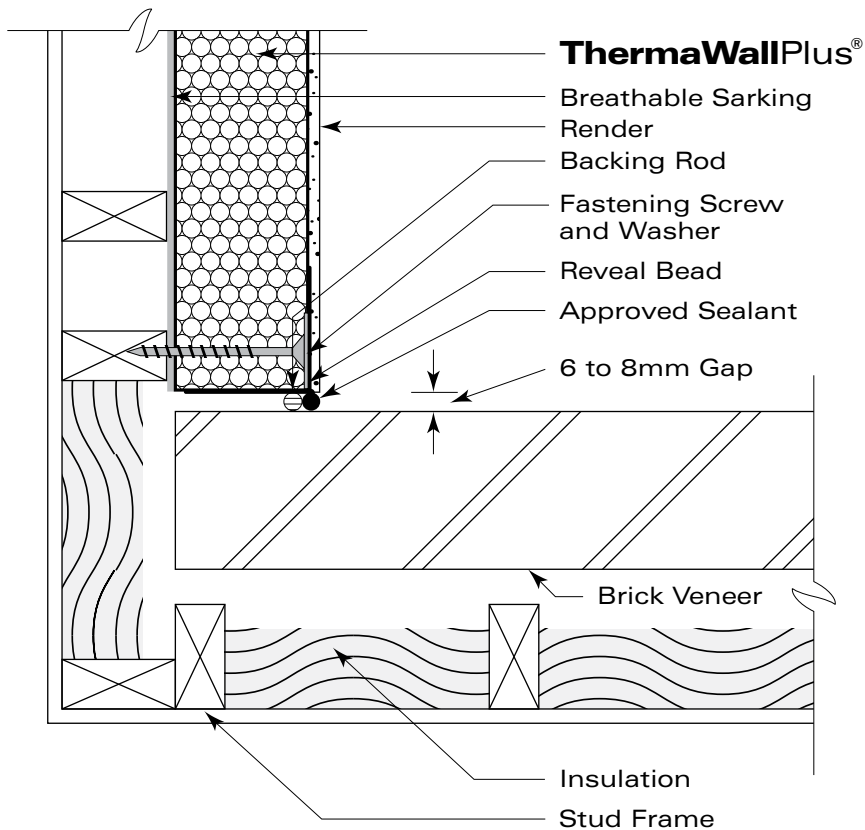

ThermaWallPlus® Panel to Brick - Internal Corner

Expansion (Control) Joints

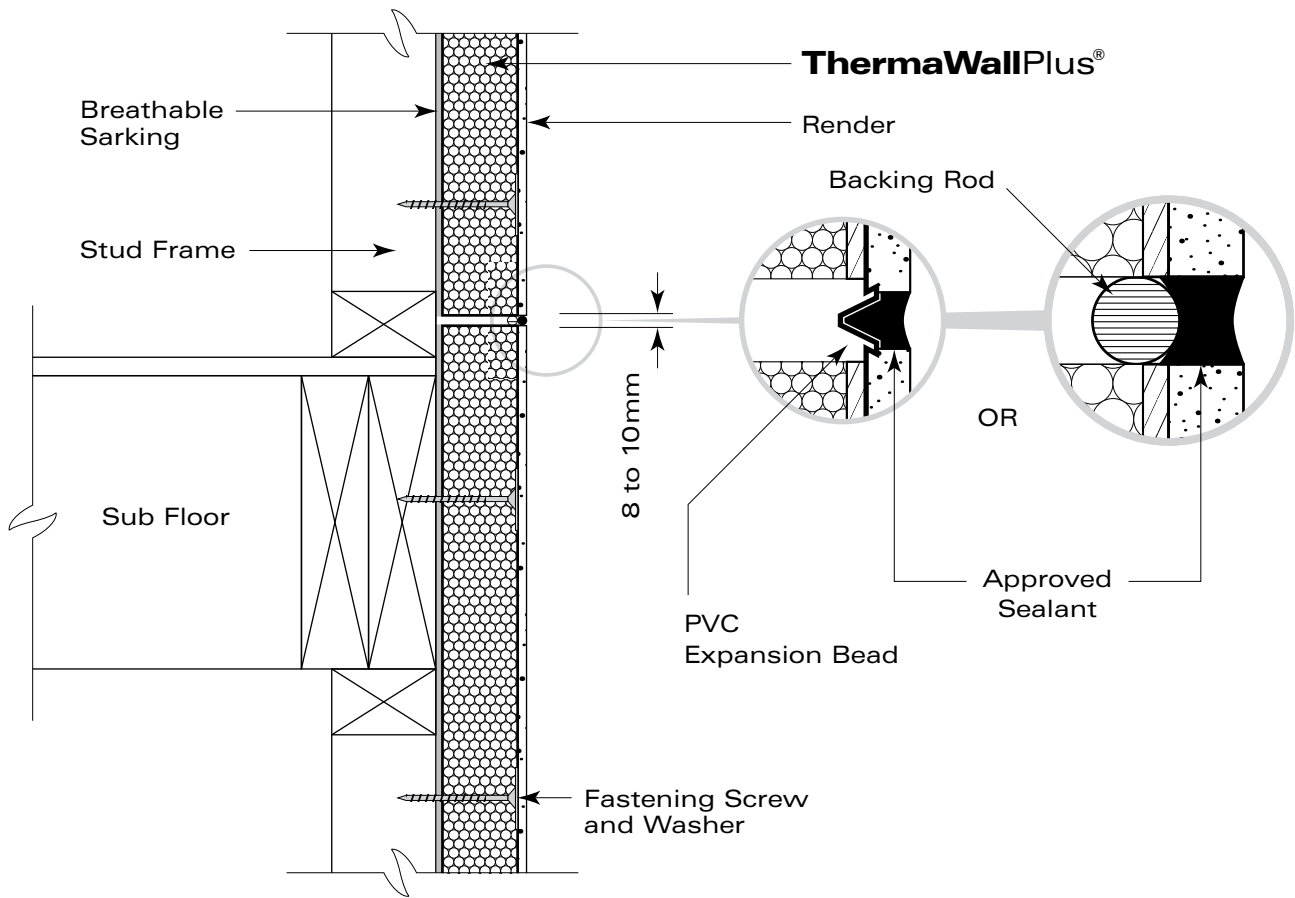

Horizontal Control Joint

Expansion (Control) Joints

Prior to installation determine expansion joint placement by consulting with a Design Engineer to calculate the deformation/stress due to soil/structure movement, deflection due to load bearing on roofing structures and to specify location of expansion/control joints.

Placement Guide: The following is a guide only and does not negate the user's responsibility to consult a Design Engineer.

In line with good building practice placement of vertical expansion joints should not exceed 5 metres where the wall length is greater than 8 metres. Joints should be placed to align with large door and window openings and internal corners. Double studs are necessary at all vertical expansion joints.

Horizontal expansion joints should not exceed 3 metres.

Expansion joints must occur where ThermaWallPlus® meets other substrates/cladding materials.

INSTALLATION AND FIXING DETAILS

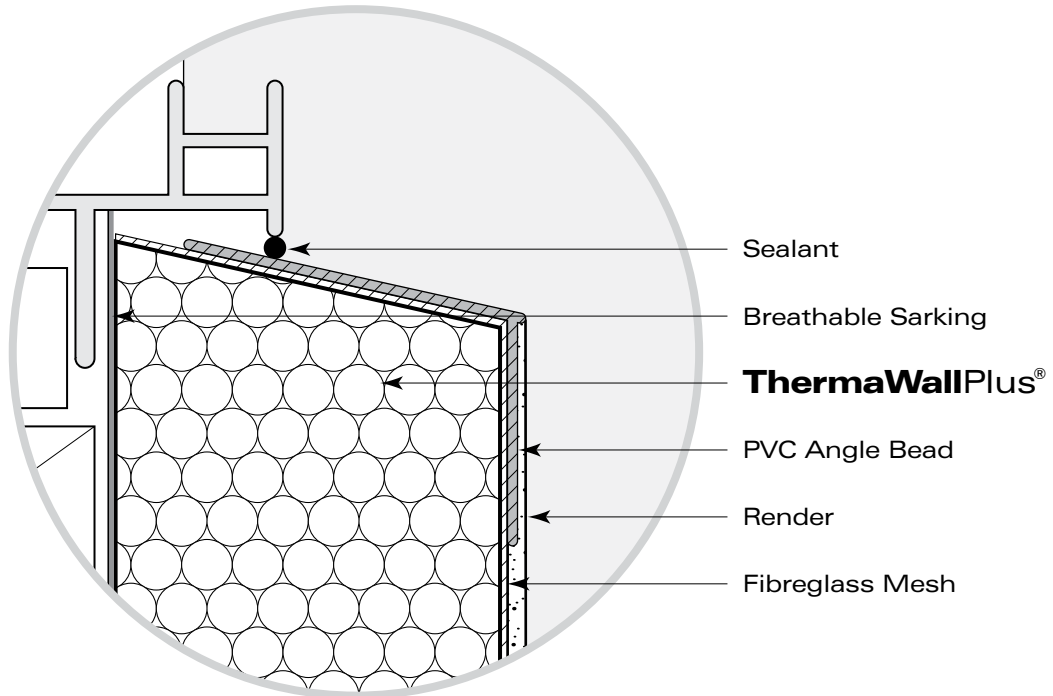

Window Sill Detail

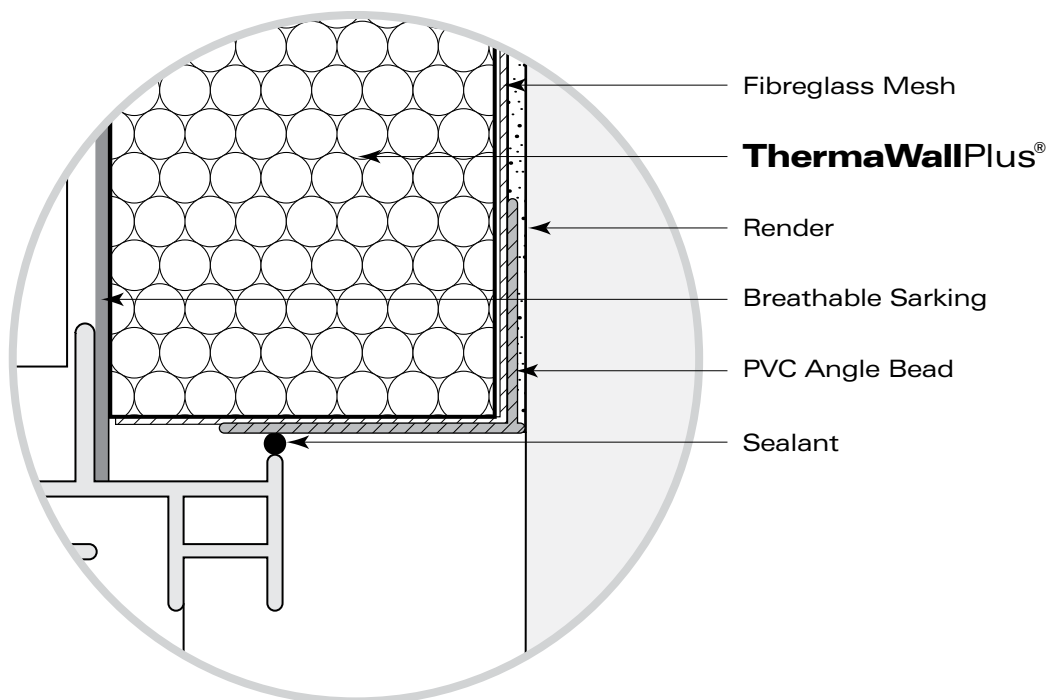

Head/Jamb Detail

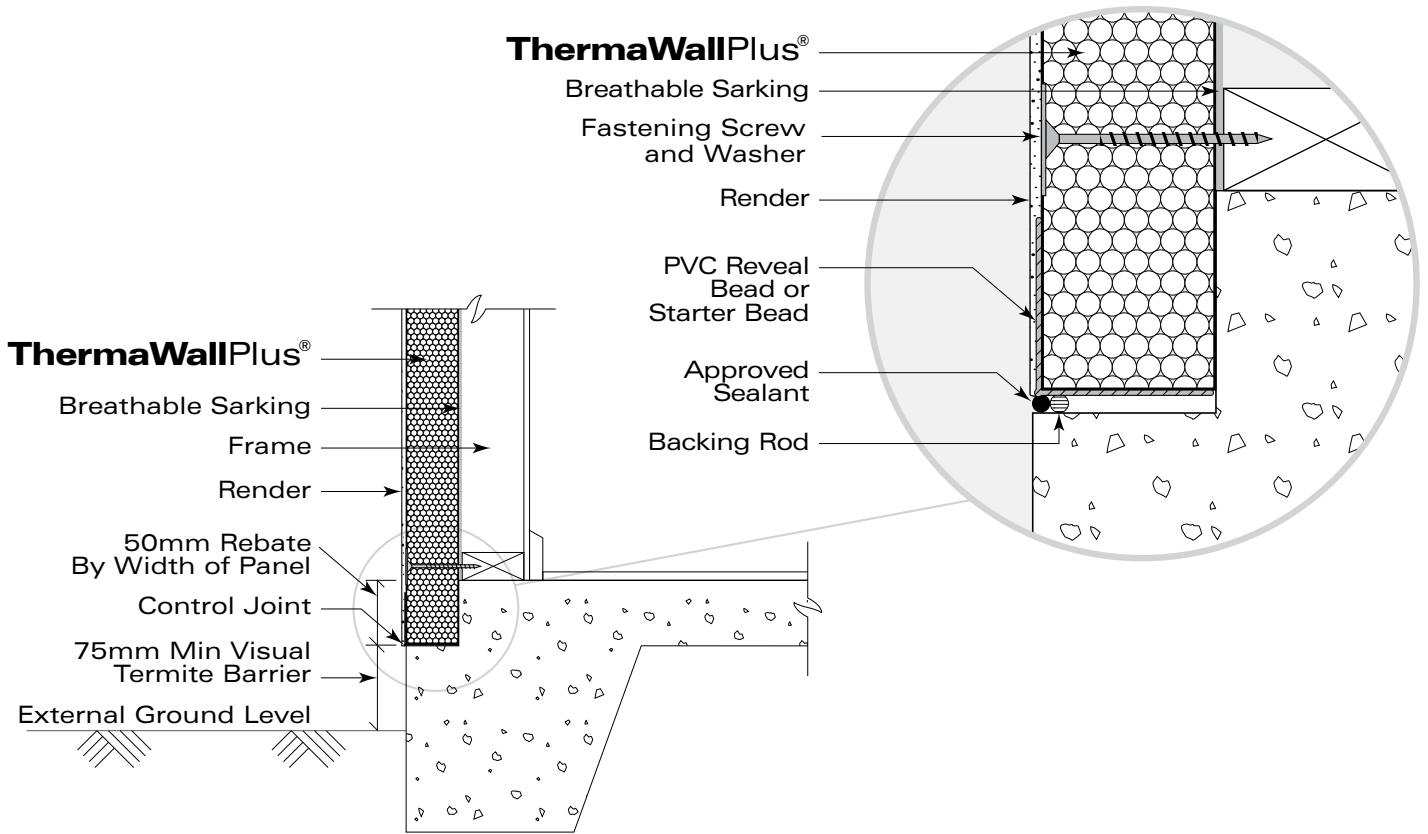

Ground Slab Rebate Detail

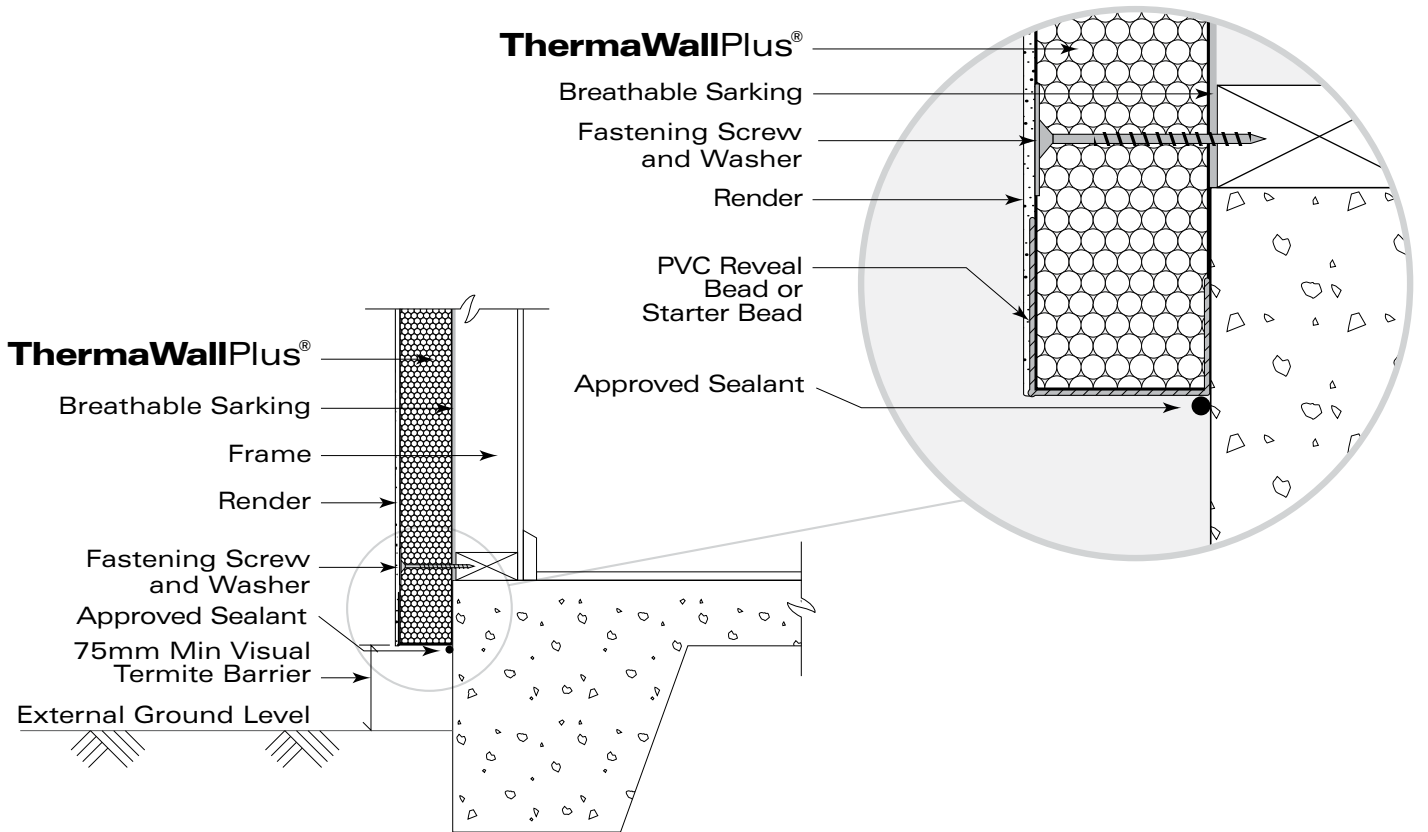

Ground Slab Edge Detail

INSTALLATION AND FIXING DETAILS

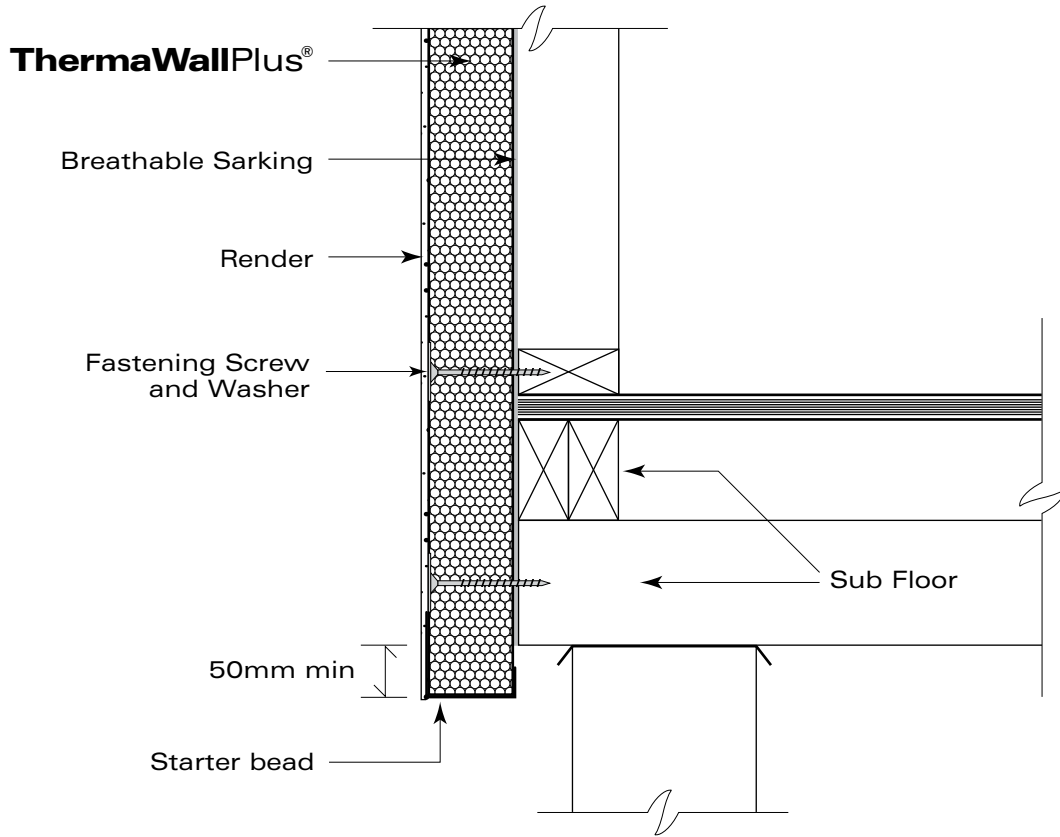

Timber Floor Junction Detail

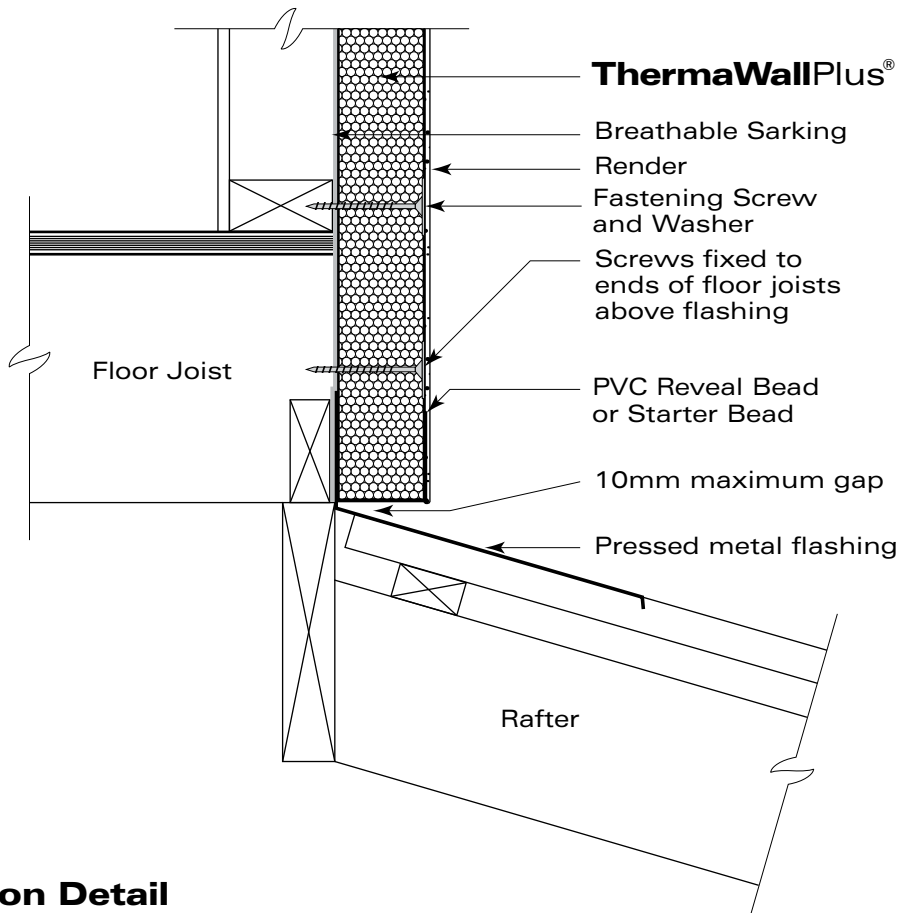

Roof Junction Detail

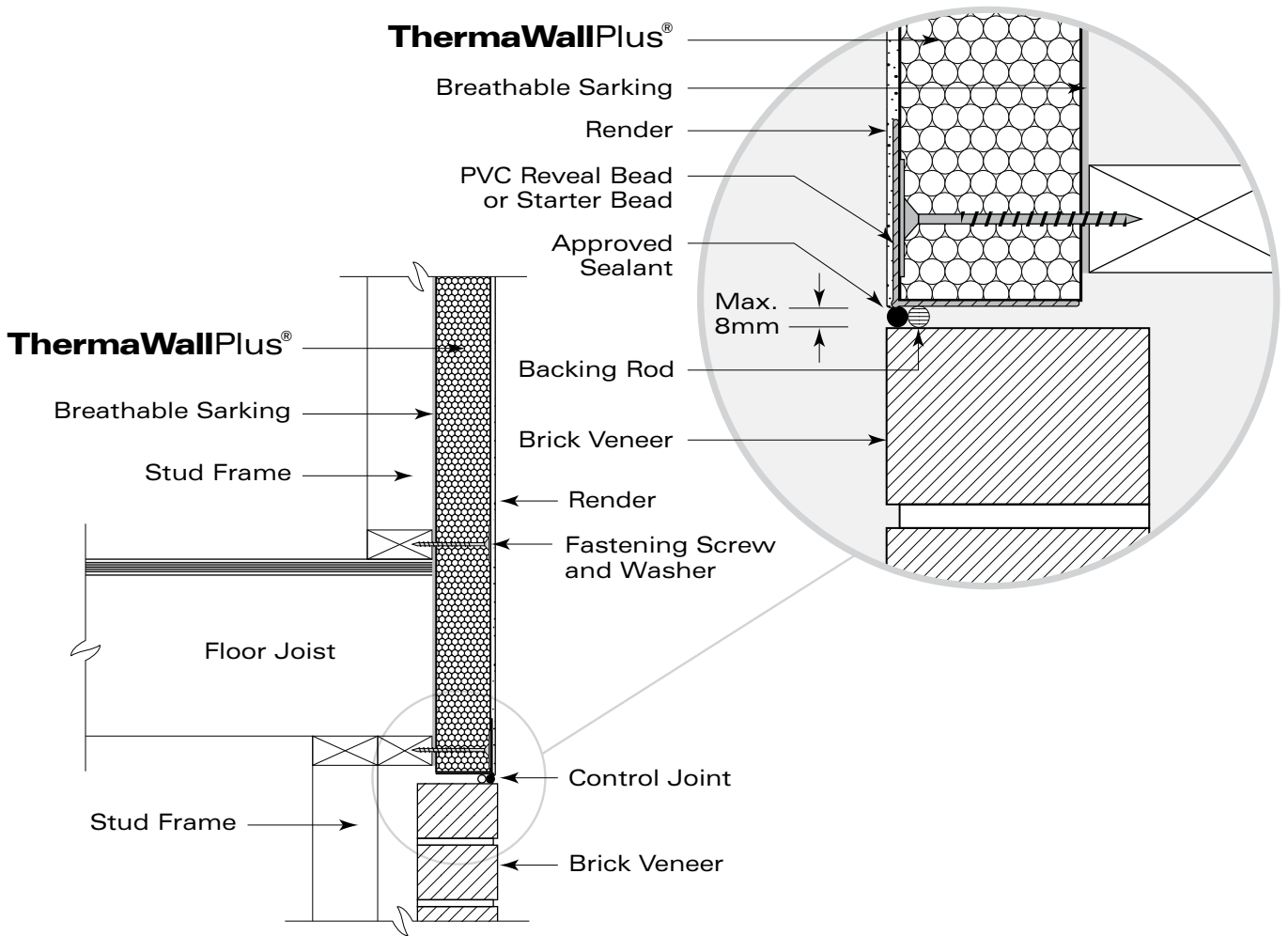

Brick Veneer Junction Detail

INSTALLATION AND FIXING DETAILS

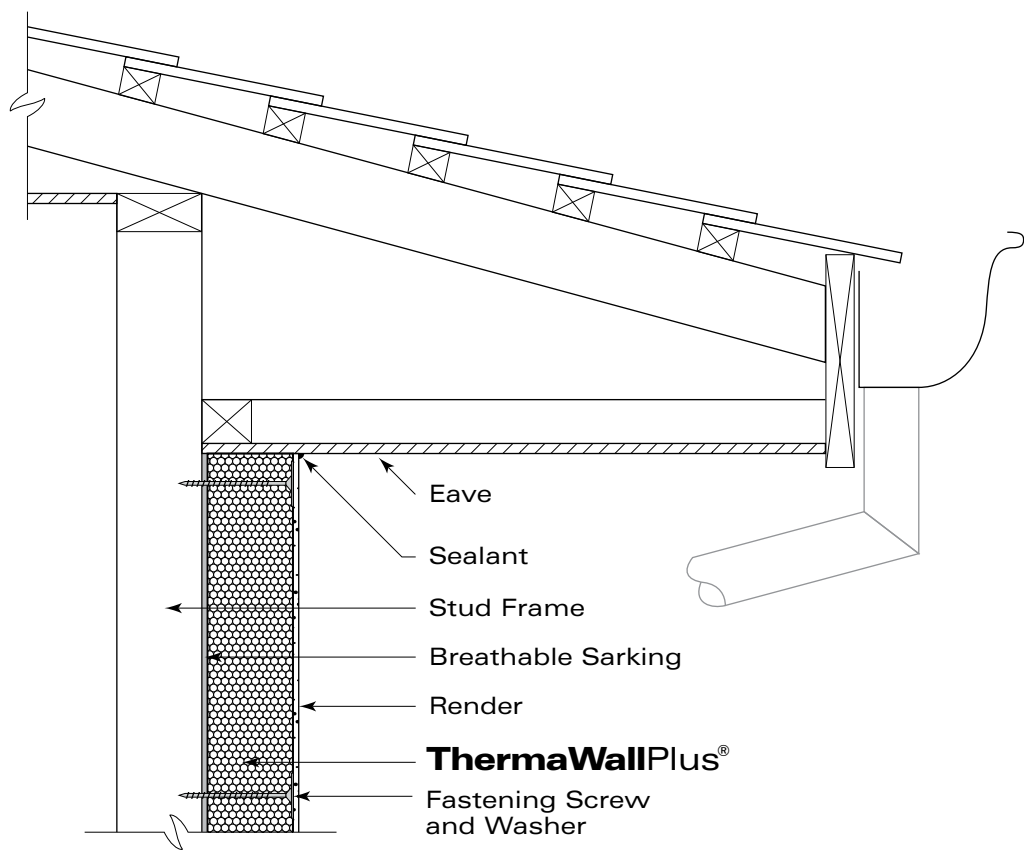

Eave Detail - Type 1

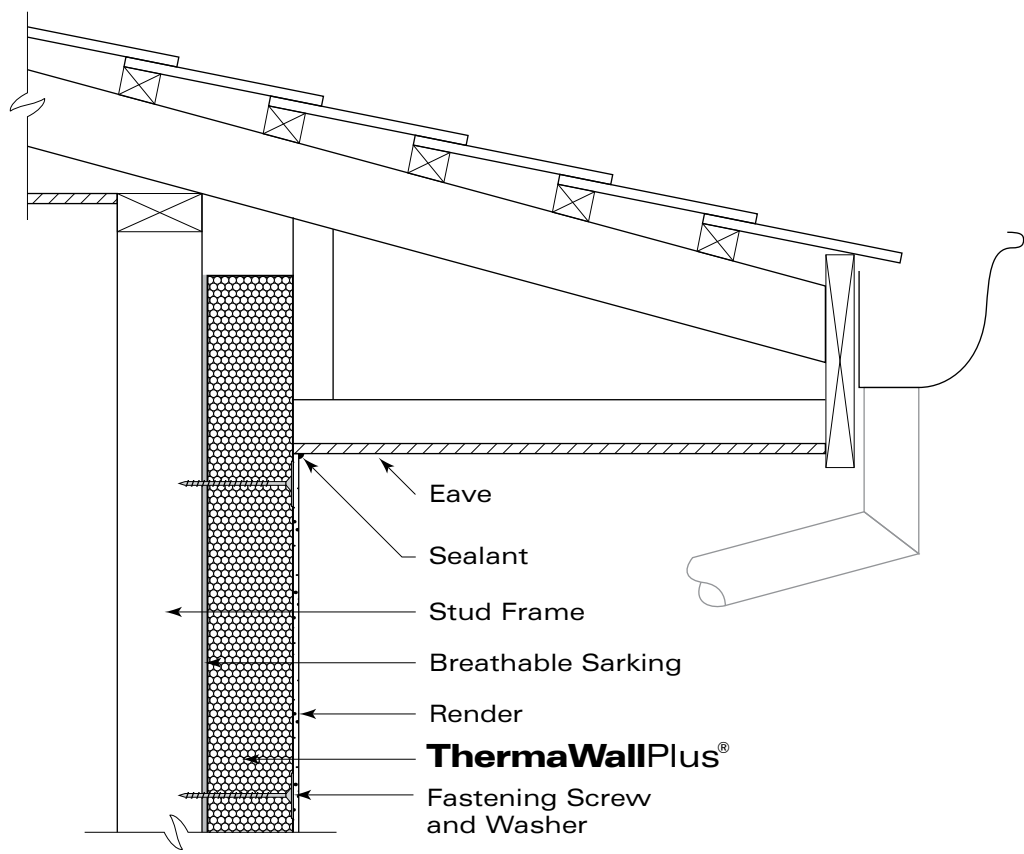

Eave Detail - Type 2

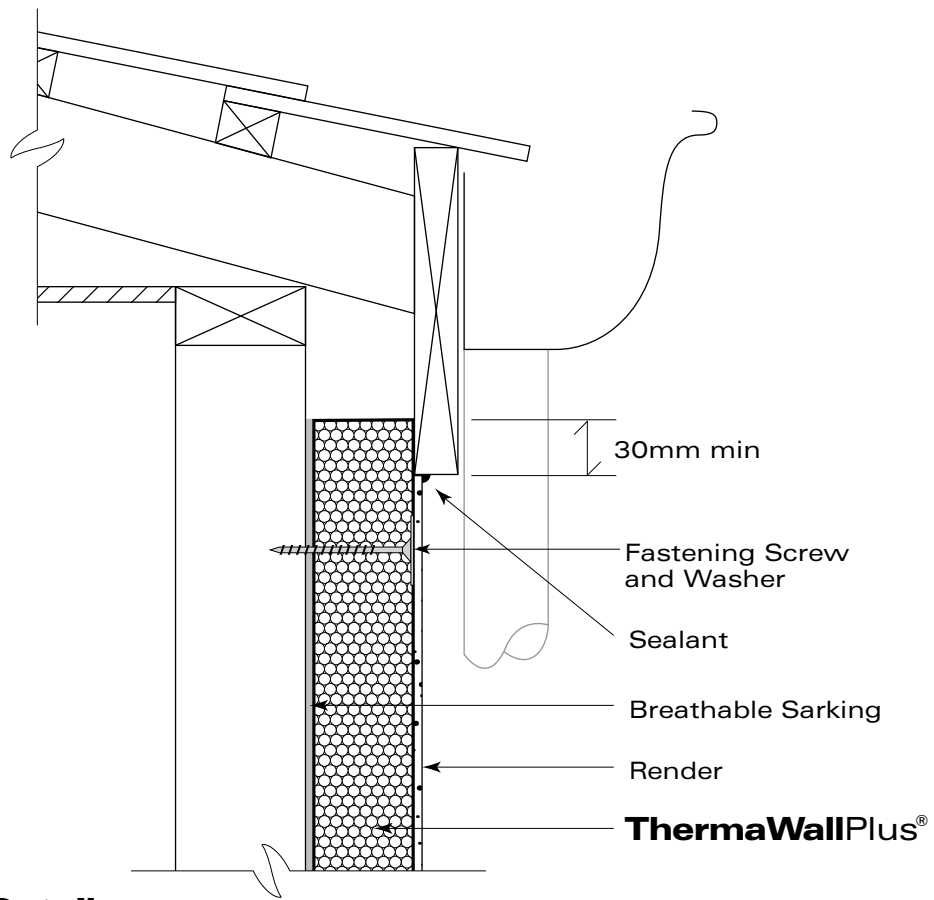

Flush Eave Detail

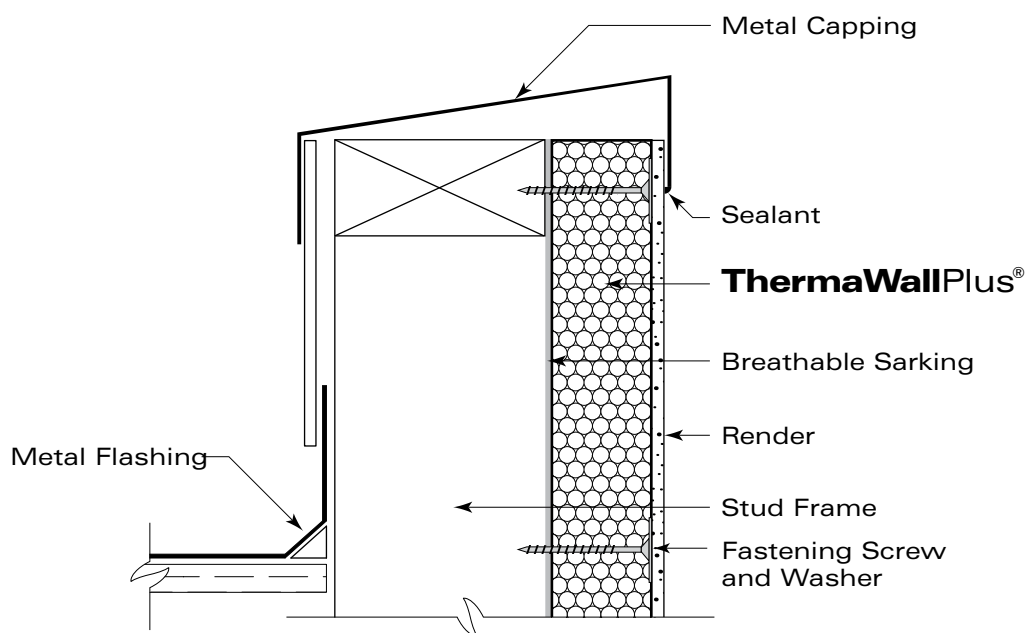

Parapet Detail

PRE-RENDER PREPARATION

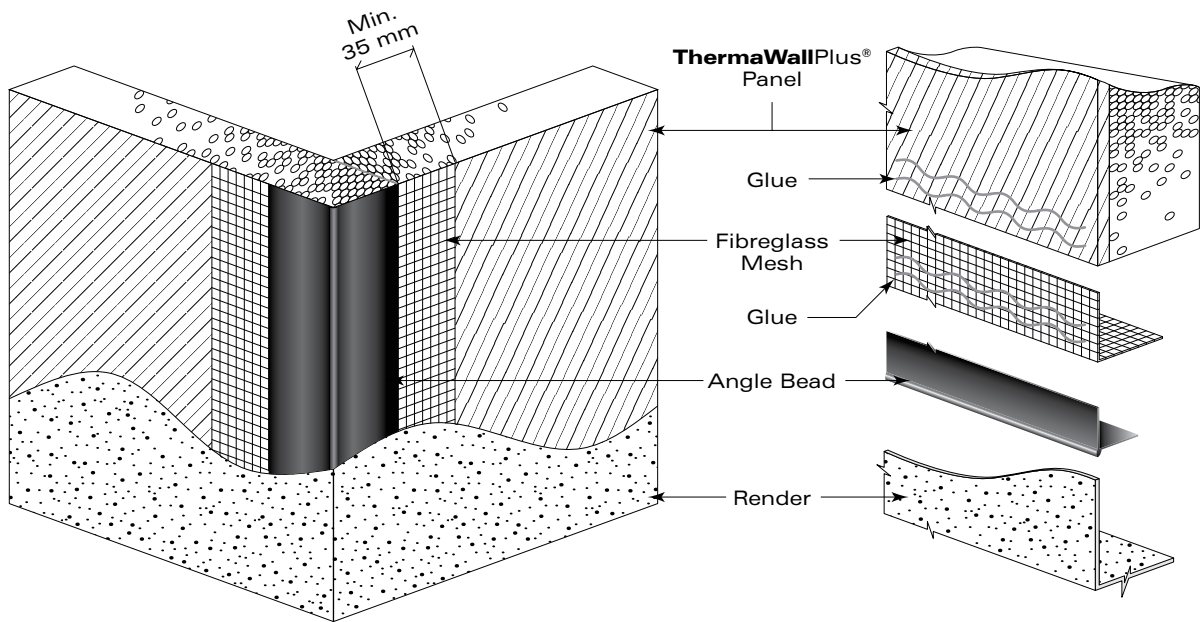

Typical Corner Detail

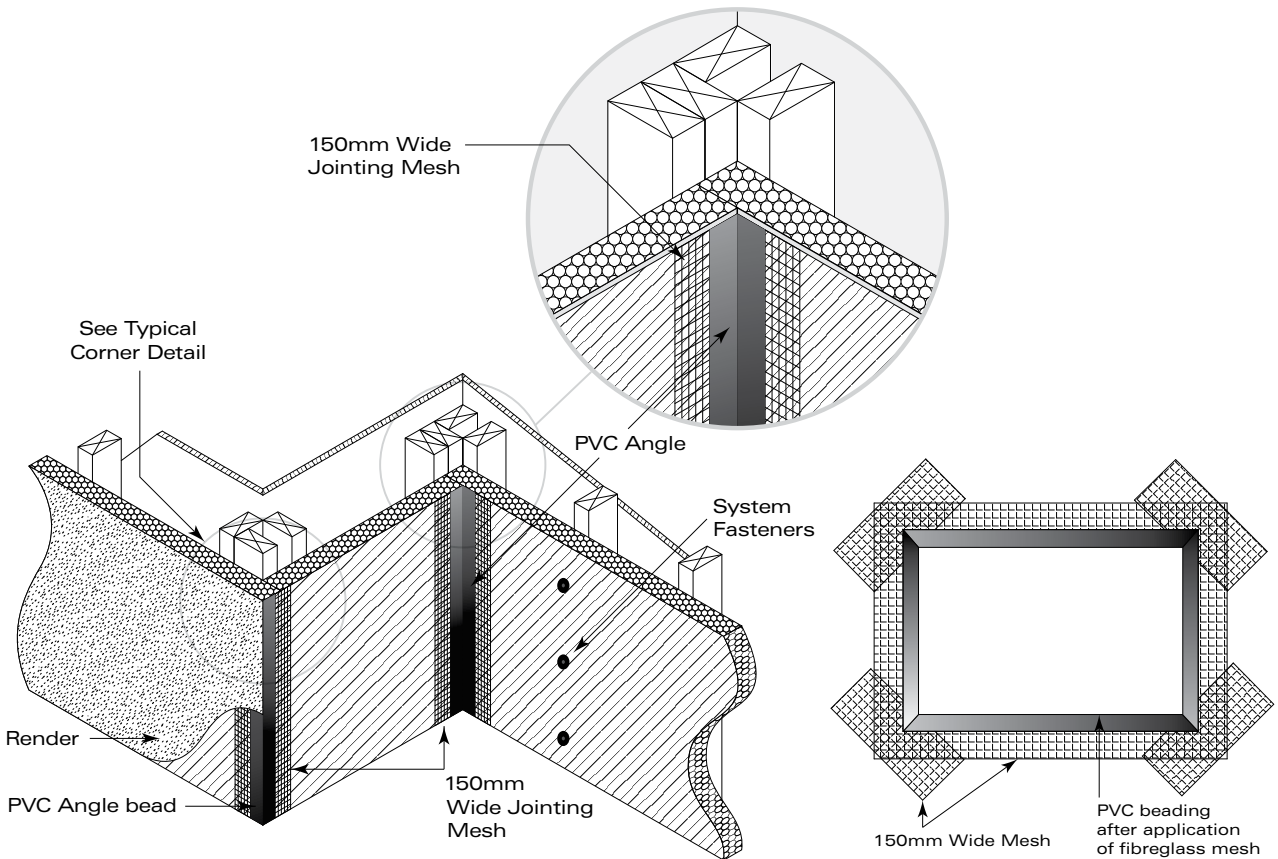

Typical Internal & External Corner Detail

Window application detail

GENERAL INFORMATION

ThermaWallPlus® Appraisals

ThermaWallPlus® building panels have been subjected to extensive testing and comply with relevant Australian building practices. Testing was completed under the previous name for ThermaWallPlus®. Refer to page 21 for Referenced Documents.

Health and Safety

Think Safe. Act Safe

To assist in maintaining a safe and healthy workplace, take note of the following:

- Ensure the workplace is safe. This includes attention to plant and equipment.
- Insist that safe work methods are practiced.
- Provide supervision and training where appropriate.
- Ensure everyone on site understands and accepts their responsibilities to promote a workplace that is safe.
- Ensure that all health and safety requirements are adhered to.

Consult your authorised Workplace Health and Safety Officer for specific advice.

Disclaimer

The information contained in this manual is presented as a guide to users of ThermaWallPlus® products, and while to the best of RMAX's knowledge it is correct and reliable, no responsibility can be taken by the company for the applications in which ThermaWallPlus® may be selected or the way in which it is used.

WARRANTY

RMAX, a division of Huntsman Chemical Company Australia Pty. Ltd. is the manufacturer of ThermaWallPlus® products.

RMAX Warranty

1. This is the sole extent of any warranty given by RMAX.
2. RMAX warrants that the ThermaWallPlus® products are free from defects caused by faulty manufacture or faulty materials for a period of 10 years from the date of sale to the Purchaser.
3. These warranties are in addition to the Purchaser's statutory rights, that it is a term of the sale to the Purchaser that to the full extent permitted by law the liability of RMAX for breach of the Purchaser's statutory rights is limited solely to any one or more of the following as determined by RMAX in its sole discretion, namely:
 - (i) supply of replacement products or similar products;
 - (ii) the repair of the products; or
 - (iii) to pay for the costs of replacement or repair of the products.
4. Except as provided in 3, RMAX will in no circumstances be liable for any loss or damage, whether direct or indirect (including consequential loss, economic or financial loss) to persons or property howsoever arising and whether from any defect in or unsuitability of a product or from negligence on the part of RMAX or any of its servants, contractors or agents.

In particular, RMAX will not be responsible for any loss or damage arising from normal wear and tear, weather conditions, any act of God, poor installation or rendering or caused by wildlife or organisms.
5. RMAX is not, and will not be, responsible or liable to any person in any manner whatsoever for incorrect fixing, joining, installing, finishing and/or rendering by any person.

REFERENCED DOCUMENTS AND INFORMATION

Referenced documents

1. ThermaWallPlus® - Wall Cladding Cyclonic Region Performance Test Report. Vipac Engineers & Scientists Ltd Melbourne Victoria 3/08/2011.
2. ThermaWallPlus® 75mm Thick - Wall Cladding Performance Test - Report Vipac Engineers & Scientists Ltd Melbourne Victoria - 5/06/2011.
3. Test for Water Penetration - ThermaWallPlus® to AS/NZS 4284:2008. Vipac Engineers & Scientists Ltd Melbourne Victoria 9/08/2010.
4. AWTA Cone Calorimeter Test Report for ThermaWallPlus® AWTA Product testing - 21/09/2009.
5. "EXIN wall panels: racking capacity of Ecotex wall panels" - Arup Facade Engineering - 24/10/2001.
6. "EXIN wall panels: Bending capacity of Ecotex wall panels and fastener pullout - Regions A, B and C of Australia" - Arup Facade Engineering - 06/12/2001.
7. "Static and repeated load tests on wall panels" - Uni Quest Limited - University of Queensland/Department of Civil Engineering - 20/04/2000.
8. "Compression tests on polystyrene foam and load tests on wall panels" - Uni Quest Limited - University of Queensland/Department of Civil Engineering - 20/06/1999.
9. "Load tests on wall panels" - Uni Quest Limited - University of Queensland/Department of Civil Engineering - 25/09/1998.
10. RMIT University Melbourne RMAX Orange Board® Sound Reduction Index Test Report to AS 1192 - 2002 for Full Wall System and Iterations 11/3/2011.

Please Note: Tests 5 through 9 were completed under the previous name for ThermaWallPlus®.

Perform Guard®

Perform Guard® EPS has been tested against termites. Perform Guard® is protected under U.S. Patents No. 5,194,323 and No. 5,270,108 Copyright © AFM Corporation 2001. All rights reserved. 2/01 R-Control, Perform Guard® and Do-All-Ply are registered trademarks of AFM Corporation, Excelsior, MN Perform Guard® EPS Copyright © AFM Corporation USA. R-Control, Perform Guard® are registered trademarks AFM Corporation USA.